

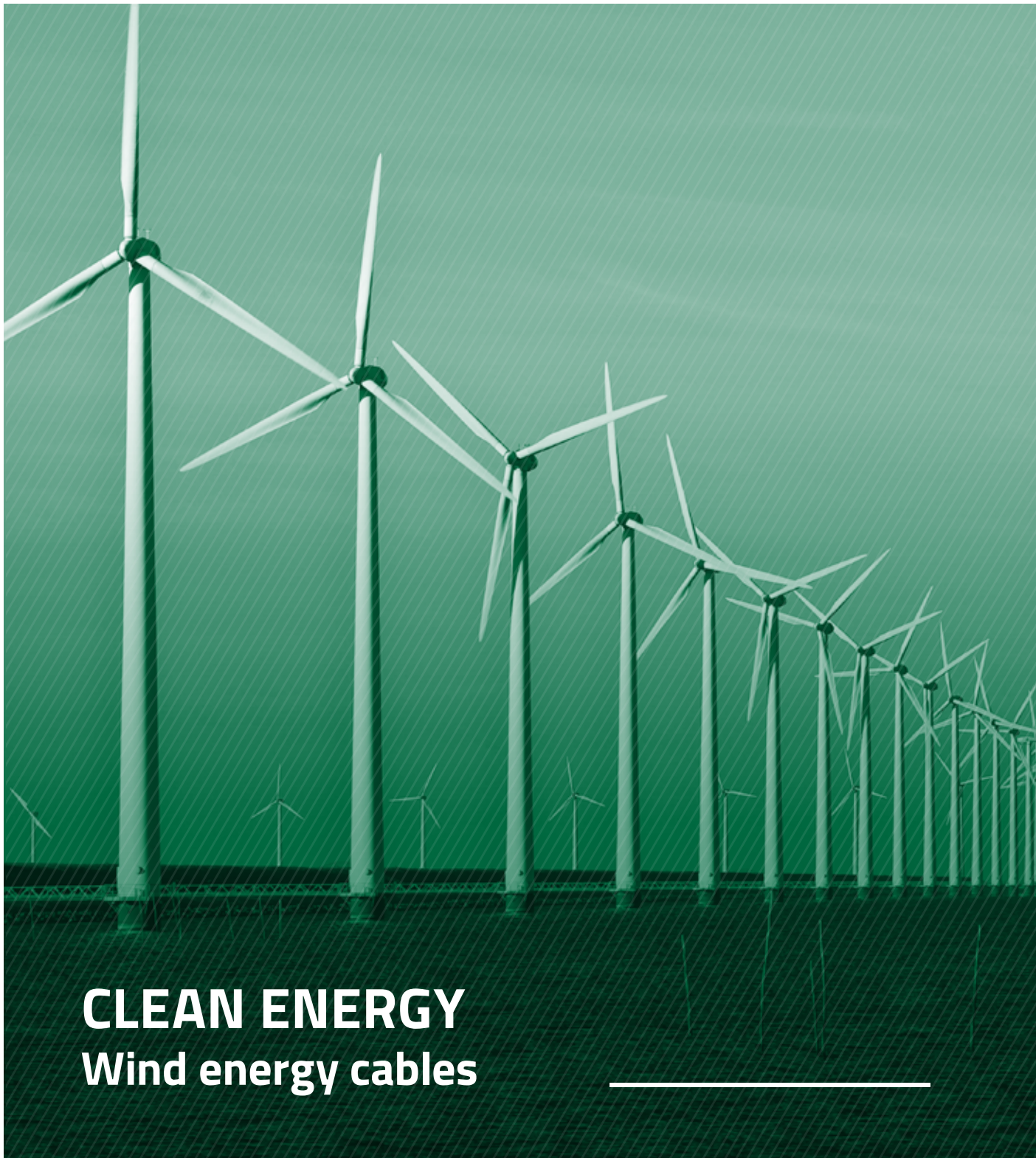

Connecting globally



**CLEAN ENERGY**  
**Wind energy cables**

# Table of Contents

<b>TELE-FONIKA KABLE</b>	<b>4</b>
<b>PRODUCTION POTENTIAL</b>	<b>5</b>
<b>CLEAN ENERGY</b>	<b>6</b>
<b>DESCRIPTION OF PICTOGRAMS USED IN CATALOGUE</b>	<b>7</b>
<b>MEDIUM VOLTAGE CABLES</b>	<b>8</b>
MEDIUM VOLTAGE XLPE POWER CABLES	10
MEDIUM VOLTAGE XLPE POWER CABLES	13
MEDIUM VOLTAGE XLPE POWER CABLES – Longitudinally Sealed	16
MEDIUM VOLTAGE XLPE POWER CABLES – Longitudinally Sealed	19
MEDIUM VOLTAGE XLPE POWER CABLES – Longitudinally and Radially Sealed	22
MEDIUM VOLTAGE XLPE POWER CABLES – Longitudinally and Radially Sealed	25
MEDIUM VOLTAGE XLPE POWER CABLES	28
MEDIUM VOLTAGE XLPE POWER CABLES	31
MEDIUM VOLTAGE XLPE POWER CABLES – Longitudinally Sealed	34
MEDIUM VOLTAGE XLPE POWER CABLES – Longitudinally Sealed	37
MEDIUM VOLTAGE XLPE POWER CABLES – Longitudinally and Radially Sealed	40
MEDIUM VOLTAGE XLPE POWER CABLES – Longitudinally and Radially Sealed	43
MEDIUM VOLTAGE XLPE POWER CABLES	46
MEDIUM VOLTAGE XLPE POWER CABLES	49
MEDIUM VOLTAGE XLPE POWER CABLES – Longitudinally Sealed	52
MEDIUM VOLTAGE XLPE POWER CABLES – Longitudinally Sealed	55
MEDIUM VOLTAGE XLPE POWER CABLES – Longitudinally and Radially Sealed	58
MEDIUM VOLTAGE XLPE POWER CABLES – Longitudinally and Radially Sealed	61
MEDIUM VOLTAGE XLPE POWER CABLES – Longitudinally and Radially Sealed	64
<b>HIGH-VOLTAGE CABLES</b>	<b>70</b>
HIGH-VOLTAGE XLPE CABLES	72
HIGH-VOLTAGE XLPE CABLES	74
HIGH-VOLTAGE XLPE CABLES	76

# Table of Contents

HIGH-VOLTAGE XLPE CABLES	78
HIGH-VOLTAGE XLPE CABLES	80
HIGH-VOLTAGE XLPE CABLES	82
HIGH-VOLTAGE XLPE CABLES	84
HIGH-VOLTAGE XLPE CABLES	86
HIGH-VOLTAGE XLPE CABLES	88
HIGH-VOLTAGE XLPE CABLES	90
HIGH-VOLTAGE XLPE CABLES	92
HIGH-VOLTAGE XLPE CABLES	94
HIGH-VOLTAGE XLPE CABLES	96
<b>Rubber Cables For Wind Farms</b>	<b>98</b>
H07ZZ-F WIND	100
DLO TORSIONFLEX RHH/RHW-2 2000 V, RW90/RW90-TC 1000 V	103
NSHXAFÖ	105
<b>Opto-Telecommunication Cables For Wind Farms</b>	<b>108</b>
A-DQ(ZN)B2Y - loose tube	110
A-DQ(ZN)B2Y - central tube	112
Z-(VX)OTKtsdD, Z-(XV)OTKtsdD	114
ZKS-XXOTKtsFf	116
ZW-(NV)OTKtsdD	118
<b>CABLE DRUMS</b>	<b>120</b>

# Leading producer of cables and cable systems

---

4

The TELE-FONIKA Kable Group has been present on the domestic and international cable industry market for more than 25 years. A stable development strategy based on full diversification of outlets enabled the strengthening of the position of our company among world's leading cable companies with significant development potential.

Services and products provided by TF Kable have numerous applications in the most important industry sectors – they include more than 25,000 proven standard constructions. Furthermore, they include specialist assortment tailored to the individual needs of business partners.

Additionally, our production facilities (in Poland, Serbia and Ukraine), the Bukowno- Poland recycling plant and commercial companies (responsible for the geo-regional distribution of products) demonstrate a significant development potential. This is also true in the case of our modern fire test laboratory in Krakow-Wielicka plant, which performs several hundred flammability pre-tests annually, and a laboratory of high and extra high voltages in Bydgoszcz.

As a result of implementation of our growth strategy, in August 2017 TFKable Group acquired JDR Cable Systems Ltd, the leading manufacturer of submarine umbilicals and power cables to the global offshore energy industry.

In the world's harshest environments and ever-increasing water depths, JDR's world- leading products and services bring power and control to offshore oil, gas and renewable energy systems.

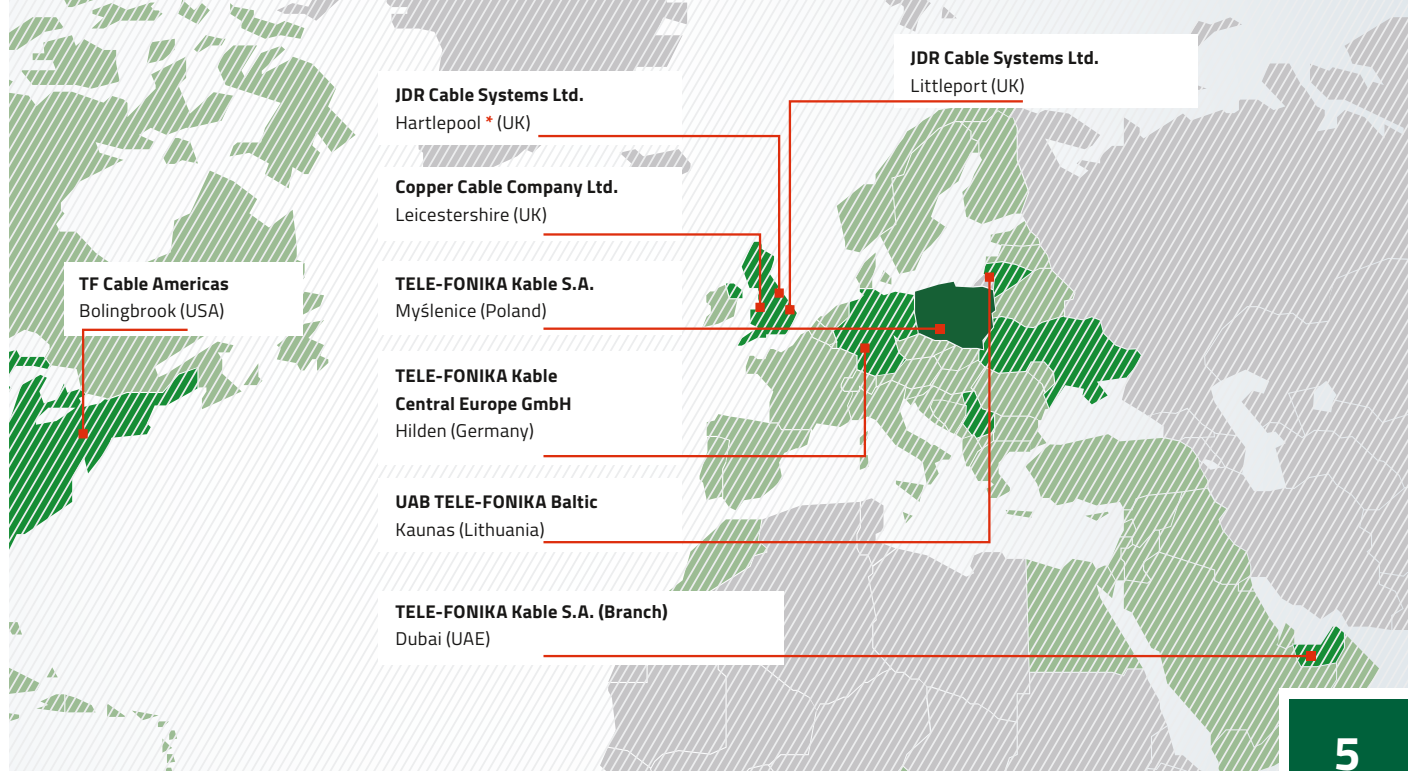

\* JDR Cable Systems Ltd. (Sales Representative) United States, UK

## Experience and competence of the TELE-FONIKA Kable Group global relations

**Kraków-Wielicka plant** – it produces cables and wires with voltage ranging from 1kV to 30kV, including rubber insulation, used in the extractive industry and wind farms; halogen-free cables and conductors (installed inside buildings); and signaling and control cables for special applications.

**Kraków-Bieżanów plant** – production of overhead lines from alloyed aluminum, silver plated copper conductors for railway traction networks, made on robotic technology lines.

**Bydgoszcz plant** – the largest production center for medium, high and extra high voltage cables in Europe  
**Myślenice plant** – production of copper and fiber optic telecommunication cables, computer cables and car cables.

**Zajecar plant (Serbia)** – production of low and medium voltage cables, signaling and control cables, telecommunication cables, as well as halogen-free cables and wires.

**Czernihiv plant (Ukraine)** – production of nonflammable (N)HXH and N2XH cables, self-supporting AsXSn overhead cables, aluminum and copper wires up to 1kV, including assembly wire

**Bukowno-Poland plant (recycling of cable waste)** – it has the recycling capacity of approx. 10 thousand tons of cable waste per year. This allows for the

recovery of fractions from individual materials with purity of over 99.5%

**Fire Test Laboratory in the Krakow-Wielicka production plant** – it is equipped with apparatus that enables to conduct research ranging from basic tests of flame spreading on individual samples to flame spreading tests on bundles. Furthermore, it is equipped for testing density of emitted fumes and emission of corrosive gases

**Laboratory of High and Extreme Voltages in the production plant in Bydgoszcz** – equipped with 4 Faraday cages (three for routine testing and one for cables and cable systems testing) along with a stroke generator and its own research field for qualification tests with 500kV testing systems and 5000A heating transformer sets

**JDR Cable Systems** – As a result of acquiring JDR Cable

Systems Limited, TFKable has expanded its assets with two UK production Facilities. JDR manufactures submarine power cables as well as subsea umbilical cables consisting of components for power distribution, data transfer, monitoring and remote control, of offshore facilities. Additionally, our sales portfolio has been extended by offshore installation and maintenance services, located in JDR's service centres in the United States and UK, ensuring constant support for our business partners.

# CLEAN ENERGY

---

6

Wind energy is the most advanced and desirable technology among all renewable energy sources. Selecting the right cables that meet strict standards and quality required for trouble-free operation of wind farms is a major challenge.

TELE-FONIA Kable has over 25 years of experience in production of special cables specifically designed for the wind energy sector. The current position of our company is a result of continuous research, development and modernization of the machinery, combined with the use of highest quality materials. TELE-FONIKA Kable only works with the best manufacturers of cable accessories, which ensures the highest quality of products supplied by us. Our experience in production and supply of renewable energy cables allows us to create a comprehensive range of products that can satisfy demands of the most demanding clients.

TELE-FONIKA Kable offers cables and wires of high and medium voltage, control cables, fiber optic cables (for data and information transfer), which are used in the construction and operation of offshore and onshore wind farms.

Our products used for construction and operation of wind farms have proven long-term durability and guarantee safe and cost-effective operation. Cables were designed to withstand long and harsh working conditions and have a proven track record of fatigue, torsion or abrasion capabilities.

We work closely with our customers in providing practical efficient solutions.

# Description of pictograms used in catalogue



Minimum and maximum exploitation temperature



Cable complies with requirements of RoHS directive



Cable conforms with the essential requirements of the applicable EC directives



Minimum and maximum installation temperature



Non-flammable sheath



Underground cable



Anti-rodent protection



UV resistant



Oil resistant



Cable designed for use in wind farms



Maximum conductor operating temperature



Humidity resistant



Halogen-free sheath



Universal cable, for outdoor and indoor installation



Cable with polyamid sheath



Outdoor cable



Fire resistance

# Medium Voltage Cables

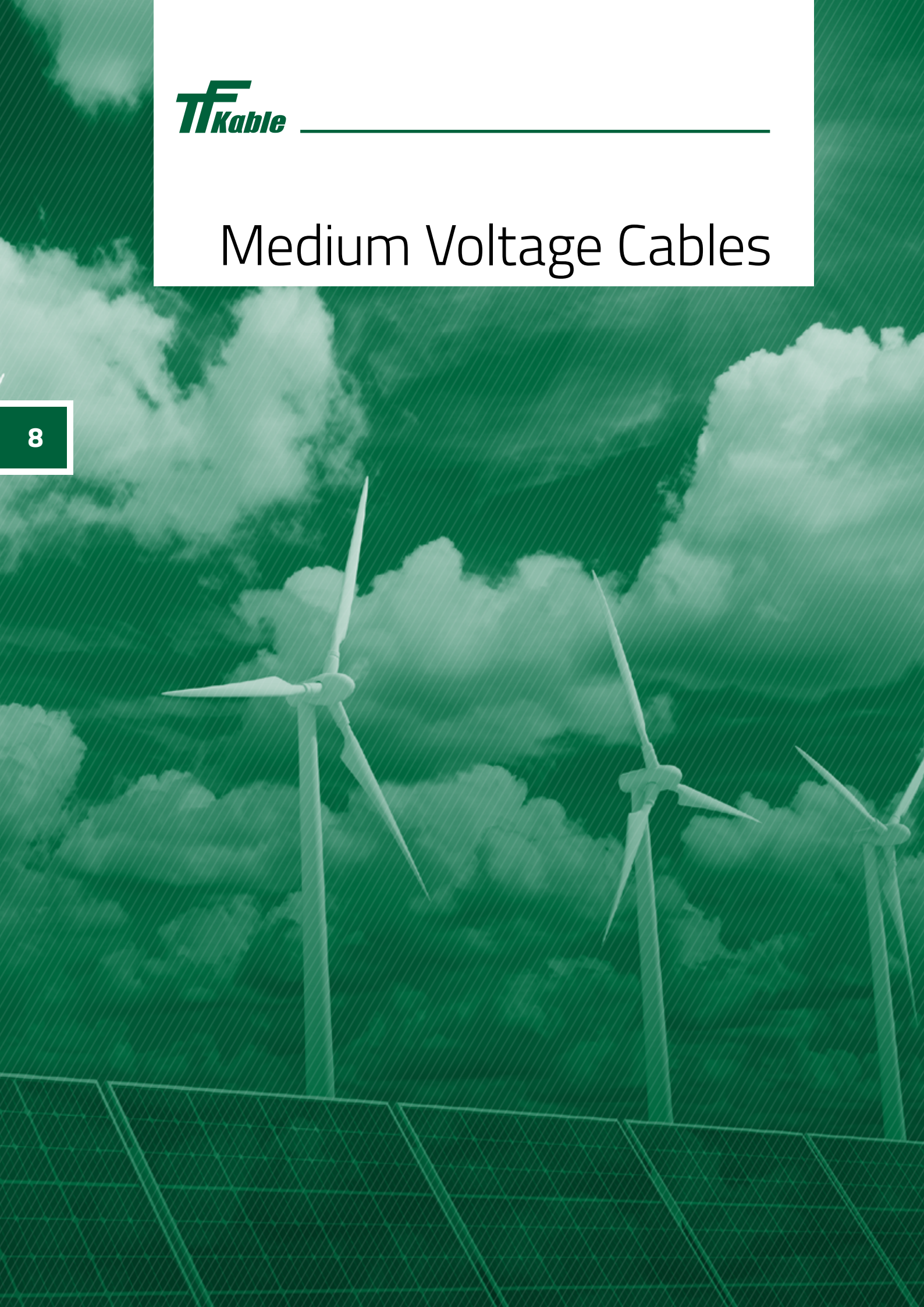

# Table of Contents

MEDIUM VOLTAGE XLPE POWER CABLES	10
MEDIUM VOLTAGE XLPE POWER CABLES	13
MEDIUM VOLTAGE XLPE POWER CABLES – Longitudinally Sealed	16
MEDIUM VOLTAGE XLPE POWER CABLES – Longitudinally Sealed	19
MEDIUM VOLTAGE XLPE POWER CABLES – Longitudinally and Radially Sealed	22
MEDIUM VOLTAGE XLPE POWER CABLES – Longitudinally and Radially Sealed	25
MEDIUM VOLTAGE XLPE POWER CABLES	28
MEDIUM VOLTAGE XLPE POWER CABLES	31
MEDIUM VOLTAGE XLPE POWER CABLES – Longitudinally Sealed	34
MEDIUM VOLTAGE XLPE POWER CABLES – Longitudinally Sealed	37
MEDIUM VOLTAGE XLPE POWER CABLES – Longitudinally and Radially Sealed	40
MEDIUM VOLTAGE XLPE POWER CABLES – Longitudinally and Radially Sealed	43
MEDIUM VOLTAGE XLPE POWER CABLES	46
MEDIUM VOLTAGE XLPE POWER CABLES	49
MEDIUM VOLTAGE XLPE POWER CABLES – Longitudinally Sealed	52
MEDIUM VOLTAGE XLPE POWER CABLES – Longitudinally Sealed	55
MEDIUM VOLTAGE XLPE POWER CABLES – Longitudinally and Radially Sealed	58
MEDIUM VOLTAGE XLPE POWER CABLES – Longitudinally and Radially Sealed	61
MEDIUM VOLTAGE XLPE POWER CABLES – Longitudinally and Radially Sealed	64

# MEDIUM VOLTAGE XLPE POWER CABLES

## 8.7/15 (17.5) kV

ALUMINIUM CONDUCTOR - Round, stranded and compacted conductor - Class 2  
A2XSX acc. to IEC 60502-2:2005 and BS 6622:2007  
YHAKXS acc. to ZN-TF-501:2002

10

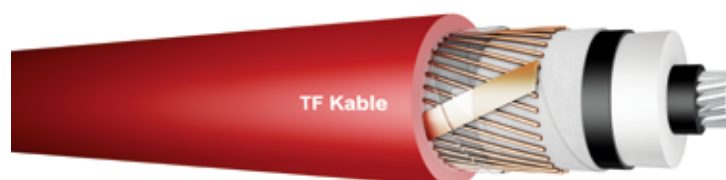

Conductor – nominal cross sectional area	Conductor diameter	Insulation		Metallic screen		Cable diameter D <sub>e</sub>	Cable weight	Maximum cable pulling force	Recommended min. bending radius for laying
		Thickness	Diameter over insulation	Cross sectional area	Diameter over metallic screen				
mm <sup>2</sup>	mm			mm <sup>2</sup>	mm	mm	kg/km	kN	m
1x50RMC	8.25 <sup>+0.10</sup>	4.5	18.5	16	22.4	27.1	780	1.5	0.41
1x70RMC	9.5 <sup>+0.20</sup>	4.5	19.7	25	23.6	28.4	950	2.1	0.43
1x95RMC	11.3 <sup>+0.20</sup>	4.5	21.5	35	25.4	30.2	1160	2.85	0.45
1x120RMC	12.5 <sup>+0.20</sup>	4.5	22.7	50	26.6	31.4	1400	3.6	0.47
1x150RMC	14.2 <sup>+0.20</sup>	4.5	24.4	50	28.3	33.1	1520	4.5	0.50
1x185RMC	15.8 <sup>+0.20</sup>	4.5	26.0	50	29.9	34.7	1660	5.55	0.52
1x240RMC	17.9 <sup>+0.10</sup>	4.5	28.1	50	32.0	36.8	1870	7.2	0.55
1x300RMC	20.0 <sup>+0.30</sup>	4.5	30.2	50	34.1	38.9	2080	9	0.58
1x400RMC	22.9 <sup>+0.30</sup>	4.5	33.1	50	37.0	41.8	2390	12	0.63
1x500RMC	25.7 <sup>+0.40</sup>	4.5	36.4	50	40.5	45.3	2810	15	0.68
1x630RMC	29.3 <sup>+0.50</sup>	4.5	40.3	50	44.4	49.3	3310	18.9	0.74
1x800RMC	33.0 <sup>+0.50</sup>	4.5	44.4	50	48.5	53.6	3920	24	0.80
1x1000RMC	38.0 <sup>+0.50</sup>	4.5	49.4	50	53.5	59.0	4680	30	0.89

# Electrical data

RM (RMC) - Round Multiwire Conductor IC (C - compacted), Class 2

SPB - Single Point Bonded

CB - Cross Bonded

BE - Both Ends

$D_e$  - Cable diameter

2 - Cables in trefoil formation, the distance between cables  $D_e$

3 - Cables in flat formation (in the ground) – the distance between cables  $D_e + 70$  mm

4 - Cables in flat formation (in the air) – the distance between cables  $2 \times D_e$

Nominal cross sectional area	Conductor resistance		Metallic screen resistance		Electrical field stress at conductor/insulation	Zero resistance $R_0$	Zero reactance $X_0$	Capacitance $C$	Capacitive reactance $X_c$	Charging current $I_c$	Inductance $L$	Inductive reactance $X_l$	Impedance
	DC 20°C	AC 90°C	DC 20°C	AC 80°C									
mm <sup>2</sup>	Ω/km				kV/mm	Ω/km	Ω/km	μF/km	kΩ/km	A/km	mH/km	Ω/km	Ω/km
1x50RMC/16	0.641	0.822	1.12	1.38	2.72/1.37	2.20	0.075	0.19	17.2	0.51	0.43	0.134	0.833
											0.73	0.229	0.853
											0.61	0.192	0.844
1x70RMC/25	0.443	0.568	0.72	0.89	2.63/1.40	1.45	0.070	0.20	15.7	0.56	0.41	0.128	0.582
											0.70	0.221	0.610
											0.59	0.186	0.598
1x95RMC/35	0.320	0.411	0.51	0.63	2.53/1.45	1.04	0.064	0.23	13.9	0.63	0.39	0.121	0.428
											0.67	0.211	0.462
											0.57	0.179	0.448
1x120RMC/50	0.253	0.325	0.36	0.44	2.48/1.47	0.77	0.061	0.25	12.9	0.67	0.37	0.117	0.345
											0.65	0.205	0.384
											0.56	0.175	0.369
1x150RMC/50	0.206	0.265	0.36	0.44	2.42/1.51	0.71	0.057	0.27	11.8	0.74	0.36	0.112	0.288
											0.63	0.198	0.331
											0.54	0.171	0.315
1x185RMC/50	0.164	0.211	0.36	0.44	2.37/1.53	0.65	0.054	0.29	10.9	0.80	0.35	0.109	0.237
											0.61	0.193	0.286
											0.53	0.167	0.269
1x240RMC/50	0.125	0.161	0.36	0.44	2.32/1.56	0.60	0.050	0.32	9.9	0.88	0.33	0.105	0.192
											0.59	0.186	0.246
											0.52	0.163	0.229
1x300RMC/50	0.100	0.130	0.36	0.44	2.28/1.59	0.57	0.047	0.35	9.1	0.96	0.32	0.101	0.164
											0.57	0.180	0.222
											0.51	0.159	0.205
1x400RMC/50	0.0778	0.102	0.36	0.44	2.24/1.61	0.54	0.044	0.39	8.1	1.07	0.31	0.097	0.141
											0.55	0.173	0.201
											0.49	0.155	0.185
1x500RMC/50	0.0605	0.0801	0.36	0.44	2.18/1.62	0.52	0.043	0.43	7.3	1.18	0.30	0.095	0.124
											0.54	0.168	0.186
											0.49	0.153	0.173
1x630RMC/50	0.0469	0.0634	0.36	0.44	2.14/1.65	0.51	0.040	0.49	6.5	1.33	0.29	0.092	0.112
											0.52	0.162	0.174
											0.48	0.150	0.163

Nominal cross sectional area	Conductor resistance		Metallic screen resistance		Electrical field stress at conductor/insulation	Zero resistance $R_0$	Zero reactance $X_0$	Capacitance $C$	Capacitive reactance $X_c$	Charging current $I_c$	Inductance $L$	Inductive reactance $X_l$	Impedance
	DC 20°C	AC 90°C	DC 20°C	AC 80°C									
Conductor/ Metallic screen	DC 20°C	AC 90°C	DC 20°C	AC 80°C	kV/mm	$\Omega$ /km	$\Omega$ /km	$\mu$ F/km	k $\Omega$ /km	A/km	mH/km	$\Omega$ /km	$\Omega$ /km
1x800RMC/50	0.0367	0.0513	0.36	0.44	2.11/1.67	0.49	0.039	0.54	5.9	1.49	0.29	0.090	0.103
											0.50	0.157	0.165
											0.47	0.148	0.156
1x1000RMC/50	0.0291	0.0427	0.36	0.44	2.08/1.69	0.49	0.036	0.61	5.2	1.67	0.28	0.087	0.097
											0.48	0.151	0.157
											0.46	0.145	0.151

## Current – carrying capacity

Nominal cross sectional area	Max short circuit capacity	GROUND				AIR				
		FLAT		TREFOIL		FLAT		TREFOIL		
		Conductor	Metallic screen	BE	SPB, CB	BE	SPB, CB	BE	SPB, CB	BE
mm <sup>2</sup>	kA/sec	A								
1x50RMC/16	4.7	3.7	224	225	212	212	230	231	196	196
1x70RMC/25	6.6	5.3	272	276	258	259	283	286	242	242
1x95RMC/35	9.0	7.1	324	333	310	312	343	350	294	295
1x120RMC/50	11.3	9.8	364	379	353	356	388	403	337	340
1x150RMC/50	14.2	9.8	407	428	397	401	440	461	384	387
1x185RMC/50	17.5	9.8	456	487	450	455	501	530	440	445
1x240RMC/50	22.7	9.8	520	567	522	530	583	627	518	526
1x300RMC/50	28.4	9.8	578	643	589	600	660	722	593	604
1x400RMC/50	37.8	9.8	650	742	676	692	758	849	692	708
1x500RMC/50	47.3	9.8	725	851	770	793	862	991	802	825
1x630RMC/50	59.5	9.8	808	979	876	908	981	1161	931	963
1x800RMC/50	75.6	9.8	889	1116	983	1028	1101	1347	1065	1110
1x1000RMC/50	94.5	9.8	971	1262	1093	1152	1225	1558	1210	1271

## Operating Conditions

For laying in ground		For installation in air	
Depth of lay:	0,7 m.	Ambient temperature:	30°C
Ground temperature:	20°C	Protection from direct solar radiation	
Soil thermal resistivity:	1/ 2,5 K · m/W		

# MEDIUM VOLTAGE XLPE POWER CABLES

## 8.7/15 (17.5) kV

COPPER CONDUCTOR - Round, stranded and compacted conductor - Class 2  
2XSy acc. to IEC 60502-2:2005 and BS 6622:2007  
YHKXS acc. to ZN-TF-501:2002

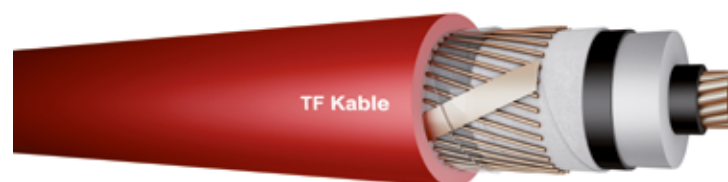

Conductor – nominal cross sectional area	Conductor diameter	Insulation		Metallic screen		Cable diameter D <sub>e</sub>	Cable weight	Maximum cable pulling force	Recommended min. bending radius for laying
		Thickness	Diameter over insulation	Cross sectional area	Diameter over metallic screen				
mm <sup>2</sup>	mm			mm <sup>2</sup>	mm	mm	kg/km	kN	m
1x35RMC	7.0 <sup>+0.15</sup>	4.5	17.2	16	21.1	25.9	920	1.75	0.39
1x50RMC	8.25 <sup>+0.20</sup>	4.5	18.5	16	22.4	27.1	1060	2.5	0.41
1x70RMC	9.6 <sup>+0.20</sup>	4.5	19.8	25	23.7	28.5	1370	3.5	0.43
1x95RMC	11.5 <sup>+0.20</sup>	4.5	21.7	35	25.6	30.4	1740	4.75	0.46
1x120RMC	12.9 <sup>+0.25</sup>	4.5	23.1	50	27.0	31.8	2140	6	0.48
1x150RMC	14.5 <sup>+0.30</sup>	4.5	24.7	50	28.6	33.4	2430	7.5	0.50
1x185RMC	16.0 <sup>+0.30</sup>	4.5	26.2	50	30.1	34.9	2790	9.25	0.52
1x240RMC	18.5 <sup>+0.30</sup>	4.5	28.7	50	32.6	37.4	3350	12	0.56
1x300RMC	20.5 <sup>+0.30</sup>	4.5	30.7	50	34.6	39.4	3940	15	0.59
1x400RMC	23.5 <sup>+0.30</sup>	4.5	33.7	50	37.6	42.4	4810	20	0.64
1x500RMC	26.5 <sup>+0.40</sup>	4.5	37.2	50	41.3	46.1	5920	25	0.69
1x630RMC	30.3 <sup>+0.40</sup>	4.5	41.3	50	45.4	50.3	7290	31.5	0.75
1x800RMC	34.6 <sup>+0.50</sup>	4.5	46.0	50	50.1	55.4	9010	40	0.83
1x1000RMC	38.2 <sup>+0.40</sup>	4.5	49.6	50	53.7	59.2	10930	50	0.89

# Electrical data

RM (RMC) - Round Multiwire Conductor IC (C - compacted), Class 2

SPB - Single Point Bonded

CB - Cross Bonded

BE - Both Ends

$D_e$  - Cable diameter

2 - Cables in trefoil formation, the distance between cables  $D_e$

3 - Cables in flat formation (in the ground) – the distance between cables  $D_e + 70$  mm

4 - Cables in flat formation (in the air) – the distance between cables  $2 \times D_e$

Nominal cross sectional area	Conductor resistance		Metallic screen resistance		Electrical field stress at conductor/insulation	Zero resistance $R_0$	Zero reactance $X_0$	Capacitance $C$	Capacitive reactance $X_c$	Charging current $I_c$	Inductance $L$	Inductive reactance $X_l$	Impedance
	DC 20°C	AC 90°C	DC 20°C	AC 80°C									
mm <sup>2</sup>	Ω/km				kV/mm	Ω/km	Ω/km	μF/km	kΩ/km	A/km	mH/km	Ω/km	Ω/km
1x35RMC/16	0.524	0.668	1.12	1.38	2.84/1.32	2.05	0.082	0.17	19.1	0.46	0.45	0.141	0.683
											0.76	0.238	0.710
											0.64	0.200	0.697
1x50RMC/16	0.387	0.494	1.12	1.38	2.72/1.37	1.88	0.075	0.19	17.2	0.51	0.43	0.134	0.512
											0.73	0.229	0.544
											0.61	0.192	0.530
1x70RMC/25	0.268	0.342	0.72	0.89	2.63/1.41	1.23	0.070	0.20	15.6	0.56	0.41	0.128	0.365
											0.70	0.220	0.407
											0.59	0.186	0.389
1x95RMC/35	0.193	0.247	0.51	0.63	2.52/1.45	0.88	0.063	0.23	13.7	0.63	0.38	0.120	0.274
											0.67	0.210	0.324
											0.57	0.178	0.304
1x120RMC/50	0.153	0.196	0.36	0.44	2.46/1.48	0.64	0.060	0.25	12.7	0.69	0.37	0.116	0.228
											0.65	0.204	0.282
											0.55	0.174	0.262
1x150RMC/50	0.124	0.159	0.36	0.44	2.41/1.51	0.60	0.056	0.27	11.6	0.75	0.36	0.112	0.194
											0.63	0.197	0.253
											0.54	0.170	0.233
1x185RMC/50	0.0991	0.128	0.36	0.44	2.37/1.54	0.57	0.053	0.30	10.8	0.81	0.34	0.108	0.167
											0.61	0.192	0.230
											0.53	0.166	0.210
1x240RMC/50	0.0754	0.0979	0.36	0.44	2.31/1.57	0.54	0.049	0.33	9.6	0.90	0.33	0.103	0.142
											0.59	0.184	0.209
											0.51	0.162	0.189
1x300RMC/50	0.0601	0.0789	0.36	0.44	2.27/1.59	0.52	0.047	0.36	8.9	0.98	0.32	0.100	0.128
											0.57	0.179	0.196
											0.50	0.158	0.177
1x400RMC/50	0.0470	0.0630	0.36	0.44	2.23/1.62	0.51	0.043	0.40	7.9	1.10	0.31	0.096	0.115
											0.55	0.172	0.183
											0.49	0.154	0.167
1x500RMC/50	0.0366	0.0506	0.36	0.44	2.17/1.63	0.49	0.042	0.44	7.2	1.21	0.30	0.094	0.107
											0.53	0.167	0.174
											0.48	0.152	0.160

Nominal cross sectional area	Conductor resistance		Metallic screen resistance		Electrical field stress at conductor/insulation	Zero resistance $R_0$	Zero reactance $X_0$	Capacitance $C$	Capacitive reactance $X_c$	Charging current $I_c$	Inductance $L$	Inductive reactance $X_l$	Impedance
	DC 20°C	AC 90°C	DC 20°C	AC 80°C									
mm <sup>2</sup>	Ω/km				kV/mm	Ω/km	Ω/km	μF/km	kΩ/km	A/km	mH/km	Ω/km	Ω/km
1x630RMC/50	0.0283	0.0412	0.36	0.44	2.13/1.65	0.48	0.040	0.50	6.4	1.37	0.29	0.091	0.100
											0.51	0.160	0.166
											0.47	0.149	0.155
											0.28	0.089	0.095
1x800RMC/50	0.0221	0.0344	0.36	0.44	2.1/1.67	0.48	0.038	0.57	5.6	1.55	0.49	0.155	0.158
											0.47	0.147	0.151
											0.28	0.089	0.095
1x1000RMC/50	0.0221	0.0344	0.36	0.44	2.1/1.67	0.48	0.038	0.57	5.6	1.55	0.49	0.155	0.158
											0.47	0.147	0.151

## Current – carrying capacity

Nominal cross sectional area	Max short circuit capacity	GROUND				AIR						
				FLAT	TREFOIL			FLAT	TREFOIL			
		Conductor	Metallic screen	BE	SPB, CB	BE	SPB, CB	BE	SPB, CB	BE	SPB, CB	
mm <sup>2</sup>	kA/sec			A								
1x35RMC/16	5.0	3.7	243	245	230	230	246	248	210	211		
1x50RMC/16	7.2	3.7	288	291	273	273	296	298	252	253		
1x70RMC/25	10.0	5.3	348	356	333	334	363	370	311	313		
1x95RMC/35	13.6	7.1	413	430	400	403	438	454	380	383		
1x120RMC/50	17.2	9.8	456	491	454	460	492	523	435	440		
1x150RMC/50	21.5	9.8	505	554	510	518	555	598	495	502		
1x185RMC/50	26.5	9.8	560	628	575	586	625	685	564	574		
1x240RMC/50	34.3	9.8	634	733	667	684	725	814	665	681		
1x300RMC/50	42.9	9.8	697	830	750	773	812	935	757	779		
1x400RMC/50	57.2	9.8	773	953	849	882	920	1093	874	906		
1x500RMC/50	71.5	9.8	850	1088	957	1002	1034	1270	1003	1047		

## Operating Conditions

For laying in ground		For installation in air	
Depth of lay:	0,7 m.	Ambient temperature:	30°C
Ground temperature:	20°C	Protection from direct solar radiation	
Soil thermal resistivity:	1/ 2,5 K · m/W		

# MEDIUM VOLTAGE XLPE POWER CABLES – Longitudinally Sealed

## 8.7/15 (17.5) kV

ALUMINIUM CONDUCTOR - Round, stranded and compacted conductor - Class 2  
A2XS(F)2Y acc. to IEC 60502-2:2005 and BS 6622:2007  
XUHAKXS acc. ZN-TF-501:2002

16

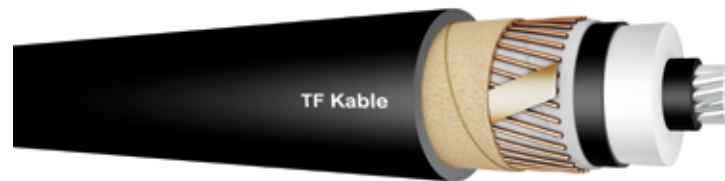

Conductor – nominal cross sectional area	Conductor diameter	Insulation		Metallic screen		Cable diameter D <sub>e</sub>	Cable weight	Maximum cable pulling force	Recommended min. bending radius for laying
		Thickness	Diameter over insulation	Cross sectional area	Diameter over metallic screen				
mm <sup>2</sup>	mm			mm <sup>2</sup>	mm	mm	kg/km	kN	m
1x50RMC	8.25 <sup>+0.10</sup>	4.5	18.5	16	22.6	28.1	720	1.5	0.42
1x70RMC	9.5 <sup>+0.20</sup>	4.5	19.7	25	23.8	29.4	890	2.1	0.44
1x95RMC	11.3 <sup>+0.20</sup>	4.5	21.5	35	25.6	31.2	1100	2.85	0.47
1x120RMC	12.5 <sup>+0.20</sup>	4.5	22.7	50	26.8	32.4	1330	3.6	0.49
1x150RMC	14.2 <sup>+0.20</sup>	4.5	24.4	50	28.5	34.1	1440	4.5	0.51
1x185RMC	15.8 <sup>+0.20</sup>	4.5	26.0	50	30.1	35.7	1580	5.55	0.54
1x240RMC	17.9 <sup>+0.10</sup>	4.5	28.1	50	32.2	37.8	1780	7.2	0.57
1x300RMC	20.0 <sup>+0.30</sup>	4.5	30.2	50	34.3	39.9	1990	9	0.60
1x400RMC	22.9 <sup>+0.30</sup>	4.5	33.1	50	37.2	42.8	2300	12	0.64
1x500RMC	25.7 <sup>+0.40</sup>	4.5	36.4	50	40.7	46.3	2710	15	0.69
1x630RMC	29.3 <sup>+0.50</sup>	4.5	40.3	50	44.6	50.3	3190	18.9	0.75
1x800RMC	33.0 <sup>+0.50</sup>	4.5	44.4	50	48.7	54.6	3780	24	0.82
1x1000RMC	38.0 <sup>+0.50</sup>	4.5	49.4	50	53.7	60.0	4510	30	0.90

# Electrical data

RM (RMC) - Round Multiwire Conductor IC (C - compacted), Class 2

SPB - Single Point Bonded

CB - Cross Bonded

BE - Both Ends

$D_e$  - Cable diameter

2 - Cables in trefoil formation, the distance between cables  $D_e$

3 - Cables in flat formation (in the ground) – the distance between cables  $D_e + 70$  mm

4 - Cables in flat formation (in the air) – the distance between cables  $2 \times D_e$

Nominal cross sectional area	Conductor resistance		Metallic screen resistance		Electrical field stress at conductor/insulation	Zero resistance $R_0$	Zero reactance $X_0$	Capacitance $C$	Capacitive reactance $X_c$	Charging current $I_c$	Inductance $L$	Inductive reactance $X_L$	Impedance
	DC 20°C	AC 90°C	DC 20°C	AC 80°C									
Conductor/ Metallic screen	DC 20°C	AC 90°C	DC 20°C	AC 80°C	kV/mm	$\Omega$ /km	$\Omega$ /km	$\mu$ F/km	k $\Omega$ /km	A/km	mH/km	$\Omega$ /km	$\Omega$ /km
mm <sup>2</sup>	$\Omega$ /km				kV/mm	$\Omega$ /km	$\Omega$ /km	$\mu$ F/km	k $\Omega$ /km	A/km	mH/km	$\Omega$ /km	$\Omega$ /km
1x50RMC/16	0.641	0.822	1.12	1.38	2.72/1.37	2.20	0.076	0.19	17.2	0.51	0.43	0.136	0.833
											0.73	0.229	0.853
											0.62	0.194	0.845
1x70RMC/25	0.443	0.568	0.72	0.89	2.63/1.40	1.45	0.070	0.20	15.7	0.56	0.41	0.130	0.583
											0.70	0.221	0.610
											0.60	0.188	0.599
1x95RMC/35	0.320	0.411	0.51	0.63	2.53/1.45	1.04	0.064	0.23	13.9	0.63	0.39	0.123	0.429
											0.67	0.212	0.462
											0.58	0.181	0.449
1x120RMC/50	0.253	0.325	0.36	0.44	2.48/1.47	0.77	0.061	0.25	12.9	0.67	0.38	0.119	0.346
											0.66	0.206	0.385
											0.56	0.177	0.370
1x150RMC/50	0.206	0.265	0.36	0.44	2.42/1.51	0.71	0.057	0.27	11.8	0.74	0.36	0.114	0.288
											0.63	0.199	0.331
											0.55	0.172	0.316
1x185RMC/50	0.164	0.211	0.36	0.44	2.37/1.53	0.65	0.054	0.29	10.9	0.80	0.35	0.110	0.238
											0.61	0.193	0.286
											0.54	0.169	0.270
1x240RMC/50	0.125	0.161	0.36	0.44	2.32/1.56	0.60	0.050	0.32	9.9	0.88	0.34	0.106	0.193
											0.59	0.187	0.247
											0.52	0.164	0.230
1x300RMC/50	0.100	0.130	0.36	0.44	2.28/1.59	0.57	0.048	0.35	9.1	0.96	0.33	0.103	0.165
											0.58	0.181	0.222
											0.51	0.161	0.206
1x400RMC/50	0.0778	0.102	0.36	0.44	2.24/1.61	0.54	0.044	0.39	8.1	1.07	0.31	0.099	0.142
											0.55	0.174	0.201
											0.50	0.157	0.187
1x500RMC/50	0.0605	0.0800	0.36	0.44	2.18/1.62	0.52	0.043	0.43	7.3	1.18	0.31	0.096	0.125
											0.54	0.169	0.187
											0.49	0.154	0.174
1x630RMC/50	0.0469	0.0634	0.36	0.44	2.14/1.65	0.51	0.041	0.49	6.5	1.33	0.30	0.093	0.113
											0.52	0.163	0.174
											0.48	0.151	0.164
1x800RMC/50	0.0367	0.0512	0.36	0.44	2.11/1.67	0.49	0.039	0.54	5.9	1.49	0.29	0.091	0.104
											0.50	0.157	0.165
											0.47	0.149	0.158
1x1000RMC/50	0.0291	0.0426	0.36	0.44	2.08/1.69	0.48	0.036	0.61	5.2	1.67	0.28	0.088	0.098
											0.48	0.151	0.157
											0.46	0.146	0.152

Nominal cross sectional area	Conductor resistance		Metallic screen resistance		Electrical field stress at conductor/insulation	Zero resistance $R_0$	Zero reactance $X_0$	Capacitance $C$	Capacitive reactance $X_c$	Charging current $I_c$	Inductance $L$	Inductive reactance $X_l$	Impedance
	DC 20°C	AC 90°C	DC 20°C	AC 80°C									
mm <sup>2</sup>	Ω/km				kV/mm	Ω/km	Ω/km	μF/km	kΩ/km	A/km	mH/km	Ω/km	Ω/km
1x630RMC/50	0.0469	0.0634	0.36	0.44	2.14/1.65	0.51	0.041	0.49	6.5	1.33	0.30	0.093	0.113
											0.52	0.163	0.174
											0.48	0.151	0.164
1x800RMC/50	0.0367	0.0512	0.36	0.44	2.11/1.67	0.49	0.039	0.54	5.9	1.49	0.29	0.091	0.104
											0.50	0.157	0.165
											0.47	0.149	0.158
1x1000RMC/50	0.0291	0.0426	0.36	0.44	2.08/1.69	0.48	0.036	0.61	5.2	1.67	0.28	0.088	0.098
											0.48	0.151	0.157
											0.46	0.146	0.152

## Current – carrying capacity

Nominal cross sectional area	Max short circuit capacity	GROUND				AIR						
		FLAT		TREFOIL		FLAT		TREFOIL				
		Conductor	Metallic screen	BE	SPB, CB	BE	SPB, CB	BE	SPB, CB	BE	SPB, CB	
mm <sup>2</sup>	kA/sec	A										
1x50RMC/16	4.7	3.7	227	228	214	214	234	235	198	198		
1x70RMC/25	6.6	5.3	276	280	261	262	288	291	245	245		
1x95RMC/35	9.0	7.1	329	337	314	315	349	357	298	299		
1x120RMC/50	11.3	9.8	369	384	357	360	396	411	342	344		
1x150RMC/50	14.2	9.8	412	433	402	406	449	469	389	393		
1x185RMC/50	17.5	9.8	462	493	455	460	511	540	446	451		
1x240RMC/50	22.7	9.8	527	574	527	536	594	639	525	533		
1x300RMC/50	28.4	9.8	586	651	595	607	673	736	601	612		
1x400RMC/50	37.8	9.8	658	751	683	700	774	865	702	717		
1x500RMC/50	47.3	9.8	734	861	778	801	880	1009	813	836		
1x630RMC/50	59.5	9.8	818	990	884	917	1003	1184	944	976		
1x800RMC/50	75.6	9.8	899	1128	992	1037	1126	1373	1080	1125		
1x1000RMC/50	94.5	9.8	983	1276	1103	1163	1255	1591	1228	1290		

## Operating Conditions

For laying in ground		For installation in air	
Depth of lay:	0,7 m.	Ambient temperature:	30°C
Ground temperature:	20°C	Protection from direct solar radiation	
Soil thermal resistivity:	1/ 2,5 K · m/W		

# MEDIUM VOLTAGE XLPE POWER CABLES – Longitudinally Sealed

## 8.7/15 (17.5) kV

COPPER CONDUCTOR - Round, stranded and compacted conductor - Class 2  
2XS(F)2Y acc. to IEC 60502-2:2005 and BS 6622:2007  
XUHKXS acc. ZN-TF-501:2002

19

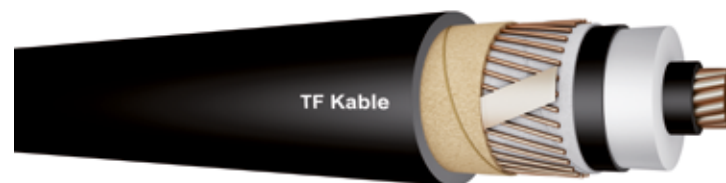

Conductor – nominal cross sectional area	Conductor diameter	Insulation		Metallic screen		Cable diameter D <sub>e</sub>	Cable weight	Maximum cable pulling force	Recommended min. bending radius for laying
		Thickness	Diameter over insulation	Cross sectional area	Diameter over metallic screen				
mm <sup>2</sup>	mm			mm <sup>2</sup>	mm	mm	kg/km	kN	m
1x35RMC	7.0 <sup>+0.15</sup>	4.5	17.2	16	21.3	26.9	860	1.75	0.40
1x50RMC	8.25 <sup>+0.20</sup>	4.5	18.5	16	22.6	28.1	1000	2.5	0.42
1x70RMC	9.6 <sup>+0.20</sup>	4.5	19.8	25	23.9	29.5	1300	3.5	0.44
1x95RMC	11.5 <sup>+0.20</sup>	4.5	21.7	35	25.8	31.4	1670	4.75	0.47
1x120RMC	12.9 <sup>+0.25</sup>	4.5	23.1	50	27.2	32.8	2070	6	0.49
1x150RMC	14.5 <sup>+0.30</sup>	4.5	24.7	50	28.8	34.4	2350	7.5	0.52
1x185RMC	16.0 <sup>+0.30</sup>	4.5	26.2	50	30.3	35.9	2710	9.25	0.54
1x240RMC	18.5 <sup>+0.30</sup>	4.5	28.7	50	32.8	38.4	3260	12	0.58
1x300RMC	20.5 <sup>+0.30</sup>	4.5	30.7	50	34.8	40.4	3850	15	0.61
1x400RMC	23.5 <sup>+0.30</sup>	4.5	33.7	50	37.8	43.4	4720	20	0.65
1x500RMC	26.5 <sup>+0.40</sup>	4.5	37.2	50	41.5	47.1	5810	25	0.71
1x630RMC	30.3 <sup>+0.40</sup>	4.5	41.3	50	45.6	51.3	7160	31.5	0.77
1x800RMC	34.6 <sup>+0.50</sup>	4.5	46.0	50	50.3	56.4	8860	40	0.85
1x1000RMC	38.2 <sup>+0.40</sup>	4.5	49.6	50	53.9	60.2	10760	50	0.90

# Electrical data

RM (RMC) - Round Multiwire Conductor IC (C - compacted), Class 2

SPB - Single Point Bonded

CB - Cross Bonded

BE - Both Ends

$D_e$  - Cable diameter

2 - Cables in trefoil formation, the distance between cables  $D_e$

3 - Cables in flat formation (in the ground) – the distance between cables  $D_e + 70$  mm

4 - Cables in flat formation (in the air) – the distance between cables  $2 \times D_e$

Nominal cross sectional area	Conductor resistance		Metallic screen resistance		Electrical field stress at conductor/insulation	Zero resistance $R_0$	Zero reactance $X_0$	Capacitance $C$	Capacitive reactance $X_c$	Charging current $I_c$	Inductance L	Inductive reactance XI	Impedance
	DC 20°C	AC 90°C	DC 20°C	AC 80°C							$o^o o^2$	$o^o o^2$	$o^o o^2$
mm <sup>2</sup>	$\Omega/km$				kV/mm	$\Omega/km$	$\Omega/km$	$\mu F/km$	k $\Omega/km$	A/km	mH/km	$\Omega/km$	$\Omega/km$
1x35RMC/16	0.524	0.668	1.12	1.38	2.84/1.32	2.05	0.082	0.17	19.1	0.46	0.46	0.144	0.684
											0.76	0.239	0.710
											0.64	0.202	0.698
1x50RMC/16	0.387	0.494	1.12	1.38	2.72/1.37	1.88	0.076	0.19	17.2	0.51	0.43	0.136	0.512
											0.73	0.229	0.544
											0.62	0.194	0.531
1x70RMC/25	0.268	0.342	0.72	0.89	2.63/1.41	1.23	0.070	0.20	15.6	0.56	0.41	0.130	0.366
											0.70	0.221	0.407
											0.60	0.188	0.390
1x95RMC/35	0.193	0.247	0.51	0.63	2.52/1.45	0.88	0.064	0.23	13.7	0.63	0.39	0.122	0.275
											0.67	0.211	0.324
											0.57	0.180	0.306
1x120RMC/50	0.153	0.196	0.36	0.44	2.46/1.48	0.64	0.060	0.25	12.7	0.69	0.38	0.118	0.229
											0.65	0.204	0.283
											0.56	0.176	0.263
1x150RMC/50	0.124	0.159	0.36	0.44	2.41/1.51	0.60	0.056	0.27	11.6	0.75	0.36	0.114	0.195
											0.63	0.198	0.254
											0.55	0.172	0.234
1x185RMC/50	0.0991	0.128	0.36	0.44	2.37/1.54	0.57	0.054	0.30	10.8	0.81	0.35	0.110	0.168
											0.61	0.193	0.231
											0.54	0.168	0.211
1x240RMC/50	0.0754	0.0978	0.36	0.44	2.31/1.57	0.54	0.050	0.33	9.6	0.90	0.33	0.105	0.144
											0.59	0.185	0.209
											0.52	0.163	0.190
1x300RMC/50	0.0601	0.0789	0.36	0.44	2.27/1.59	0.52	0.047	0.36	8.9	0.98	0.32	0.102	0.129
											0.57	0.180	0.196
											0.51	0.160	0.178
1x400RMC/50	0.0470	0.0629	0.36	0.44	2.23/1.62	0.51	0.044	0.40	7.9	1.10	0.31	0.098	0.116
											0.55	0.173	0.184
											0.50	0.156	0.168
1x500RMC/50	0.0366	0.0505	0.36	0.44	2.17/1.63	0.49	0.042	0.44	7.2	1.21	0.30	0.095	0.108
											0.53	0.167	0.175
											0.49	0.153	0.162

Nominal cross sectional area	Conductor resistance		Metallic screen resistance		Electrical field stress at conductor/insulation	Zero resistance $R_0$	Zero reactance $X_0$	Capacitance $C$	Capacitive reactance $X_c$	Charging current $I_c$	Inductance $L$	Inductive reactance $X_L$	Impedance
	DC 20°C	AC 90°C	DC 20°C	AC 80°C									
mm <sup>2</sup>	Ω/km				kV/mm	Ω/km	Ω/km	μF/km	kΩ/km	A/km	mH/km	Ω/km	Ω/km
1x630RMC/50	0.0283	0.0410	0.36	0.44	2.13/1.65	0.48	0.040	0.50	6.4	1.37	0.29	0.092	0.101
											0.51	0.161	0.166
											0.48	0.150	0.156
1x800RMC/50	0.0221	0.0343	0.36	0.44	2.1/1.67	0.48	0.038	0.57	5.6	1.55	0.29	0.090	0.096
											0.49	0.155	0.159
											0.47	0.148	0.152
1x1000RMC/50	0.0176	0.0296	0.36	0.44	2.08/1.69	0.47	0.036	0.62	5.2	1.68	0.28	0.088	0.093
											0.48	0.151	0.154
											0.46	0.146	0.149

## Current – carrying capacity

Nominal cross sectional area	Max short circuit capacity	GROUND				AIR					
				FLAT		TREFOIL		FLAT		TREFOIL	
		Conductor	Metallic screen	BE	SPB, CB	BE	SPB, CB	BE	SPB, CB	BE	SPB, CB
mm <sup>2</sup>	kA/sec	A									
1x35RMC/16	5.0	3.7	246	248	232	233	251	252	213	213	
1x50RMC/16	7.2	3.7	292	295	276	277	301	303	255	256	
1x70RMC/25	10.0	5.3	353	361	337	338	370	376	316	317	
1x95RMC/35	13.6	7.1	418	436	405	408	446	462	385	388	
1x120RMC/50	17.2	9.8	462	497	459	465	502	533	441	446	
1x150RMC/50	21.5	9.8	512	561	516	524	566	609	501	509	
1x185RMC/50	26.5	9.8	568	636	581	593	638	698	571	582	
1x240RMC/50	34.3	9.8	643	742	675	692	740	830	674	690	
1x300RMC/50	42.9	9.8	707	840	758	782	829	953	767	790	
1x400RMC/50	57.2	9.8	783	964	858	891	940	114	886	918	
1x500RMC/50	71.5	9.8	861	1100	966	1011	1056	1294	1016	1061	
1x630RMC/50	90.1	9.8	947	1256	1083	1144	1184	1508	1164	1224	
1x800RMC/50	114.4	9.8	1027	1417	1196	1277	1309	1738	1314	1395	
1x1000RMC/50	143.0	9.8	1095	1570	1295	1395	1417	1957	1446	1549	

## Operating Conditions

For laying in ground		For installation in air	
Depth of lay:	0,7 m.	Ambient temperature:	30°C
Ground temperature:	20°C	Protection from direct solar radiation	
Soil thermal resistivity:	1/ 2,5 K · m/W		

# MEDIUM VOLTAGE XLPE POWER CABLES – Longitudinally and Radially Sealed

## 8.7/15 (17.5) kV

22

ALUMINIUM CONDUCTOR - Round, stranded and compacted conductor - Class 2  
A2XS(FL)2Y acc. to IEC 60502-2:2005 and BS 6622:2007  
XRUHAKXS acc. ZN-TF-501:2002

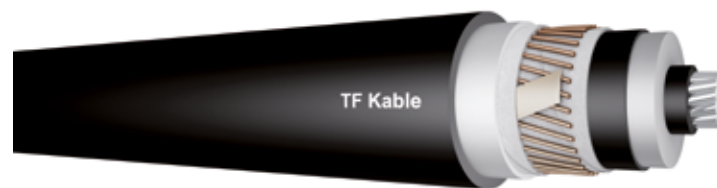

Conductor – nominal cross sectional area	Conductor diameter	Insulation		Metallic screen		Cable diameter D <sub>e</sub>	Cable weight	Maximum cable pulling force	Recommended min. bending radius for laying
		Thickness	Diameter over insulation	Cross sectional area	Diameter over metallic screen				
mm <sup>2</sup>	mm			mm <sup>2</sup>	mm	mm	kg/km	kN	m
1x50RMC	8.25 <sup>+0.10</sup>	4.5	18.5	16	22.5	28.6	780	1.5	0.60
1x70RMC	9.5 <sup>+0.20</sup>	4.5	19.7	25	23.8	29.8	950	2.1	0.63
1x95RMC	11.3 <sup>+0.20</sup>	4.5	21.5	35	25.6	31.6	1160	2.85	0.68
1x120RMC	12.5 <sup>+0.20</sup>	4.5	22.7	50	26.8	32.8	1400	3.6	0.71
1x150RMC	14.2 <sup>+0.20</sup>	4.5	24.4	50	28.5	34.5	1520	4.5	0.75
1x185RMC	15.8 <sup>+0.20</sup>	4.5	26.0	50	30.1	36.1	1660	5.55	0.79
1x240RMC	17.9 <sup>+0.10</sup>	4.5	28.1	50	32.2	38.2	1860	7.2	0.84
1x300RMC	20.0 <sup>+0.30</sup>	4.5	30.2	50	34.3	40.3	2080	9	0.89
1x400RMC	22.9 <sup>+0.30</sup>	4.5	33.1	50	37.2	43.2	2380	12	0.97
1x500RMC	25.7 <sup>+0.40</sup>	4.5	36.4	50	40.7	46.7	2800	15	1.05
1x630RMC	29.3 <sup>+0.50</sup>	4.5	40.3	50	44.5	50.8	3290	18.9	1.15
1x800RMC	33.0 <sup>+0.50</sup>	4.5	44.4	50	48.6	55.3	3910	24	1.25
1x1000RMC	38.0 <sup>+0.50</sup>	4.5	49.4	50	53.6	60.5	4630	30	1.38

# Electrical data

RM (RMC) - Round Multiwire Conductor IC (C - compacted), Class 2  
 SPB - Single Point Bonded  
 CB - Cross Bonded  
 BE - Both Ends  
 D<sub>e</sub> - Cable diameter

2 - Cables in trefoil formation, the distance between cables D<sub>e</sub>  
 3 - Cables in flat formation (in the ground) – the distance between cables D<sub>e</sub> + 70 mm  
 4 - Cables in flat formation (in the air) – the distance between cables 2 x D<sub>e</sub>

Nominal cross sectional area	Conductor resistance		Metallic screen resistance		Electrical field stress at conductor/insulation	Zero resistance R <sub>0</sub>	Zero reactance X <sub>0</sub>	Capacitance C	Capacitive reactance X <sub>c</sub>	Charging current I <sub>c</sub>	Inductance L	Inductive reactance X <sub>l</sub>	Impedance
	DC 20°C	AC 90°C	DC 20°C	AC 80°C									
Conductor/ Metallic screen	DC 20°C	AC 90°C	DC 20°C	AC 80°C	kV/mm	Ω/km	Ω/km	μF/km	kΩ/km	A/km	mH/km	Ω/km	Ω/km
mm <sup>2</sup>	Ω/km				kV/mm	Ω/km	Ω/km	μF/km	kΩ/km	A/km	mH/km	Ω/km	Ω/km
1x50RMC/16	0.641	0.822	1.12	1.38	2.72/1.37	1.63	0.078	0.19	17.2	0.51	0.44	0.137	0.833
											0.73	0.230	0.853
											0.62	0.195	0.845
1x70RMC/25	0.443	0.568	0.72	0.89	2.63/1.40	1.17	0.073	0.20	15.7	0.56	0.42	0.131	0.583
											0.71	0.222	0.610
											0.60	0.189	0.599
1x95RMC/35	0.320	0.411	0.51	0.63	2.53/1.45	0.88	0.066	0.23	13.9	0.63	0.39	0.124	0.429
											0.67	0.212	0.462
											0.58	0.182	0.449
1x120RMC/50	0.253	0.325	0.36	0.44	2.48/1.47	0.67	0.063	0.25	12.9	0.67	0.38	0.120	0.346
											0.66	0.206	0.385
											0.57	0.178	0.370
1x150RMC/50	0.206	0.265	0.36	0.44	2.42/1.51	0.61	0.059	0.27	11.8	0.74	0.37	0.115	0.289
											0.63	0.199	0.331
											0.55	0.173	0.316
1x185RMC/50	0.164	0.211	0.36	0.44	2.37/1.53	0.55	0.055	0.29	10.9	0.80	0.35	0.111	0.238
											0.62	0.193	0.286
											0.54	0.169	0.270
1x240RMC/50	0.125	0.161	0.36	0.44	2.32/1.56	0.50	0.052	0.32	9.9	0.88	0.34	0.107	0.193
											0.59	0.187	0.247
											0.53	0.165	0.231
1x300RMC/50	0.100	0.130	0.36	0.44	2.28/1.59	0.46	0.049	0.35	9.1	0.96	0.33	0.103	0.166
											0.58	0.181	0.223
											0.51	0.161	0.207
1x400RMC/50	0.0778	0.102	0.36	0.44	2.24/1.61	0.43	0.046	0.39	8.1	1.07	0.32	0.099	0.142
											0.55	0.174	0.202
											0.50	0.157	0.187
1x500RMC/50	0.0605	0.0800	0.36	0.44	2.18/1.62	0.40	0.044	0.43	7.3	1.18	0.31	0.097	0.126
											0.54	0.169	0.187
											0.49	0.155	0.174

Nominal cross sectional area	Conductor resistance		Metallic screen resistance		Electrical field stress at conductor/ insulation	Zero resistance $R_0$	Zero reactance $X_0$	Capacitance $C$	Capacitive reactance $X_c$	Charging current $I_c$	Inductance $L$	Inductive reactance $X_l$	Impedance
	DC 20°C	AC 90°C	DC 20°C	AC 80°C									
mm <sup>2</sup>	Ω/km				kV/mm	Ω/km	Ω/km	μF/km	kΩ/km	A/km	mH/km	Ω/km	Ω/km
1x630RMC/50	0.0469	0.0633	0.36	0.44	2.14/1.65	0.38	0.042	0.49	6.5	1.33	0.30	0.094	0.113
											0.52	0.163	0.175
											0.48	0.152	0.165
1x800RMC/50	0.0367	0.0511	0.36	0.44	2.11/1.67	0.36	0.040	0.54	5.9	1.49	0.29	0.092	0.105
											0.50	0.158	0.166
											0.48	0.150	0.158
1x1000RMC/50	0.0291	0.0425	0.36	0.44	2.08/1.69	0.34	0.037	0.61	5.2	1.67	0.28	0.088	0.098
											0.48	0.151	0.157
											0.47	0.147	0.153

## Current – carrying capacity

Nominal cross sectional area	Max short circuit capacity	GROUND				AIR						
		FLAT		TREFOIL		FLAT		TREFOIL				
		Conductor	Metallic screen	BE	SPB, CB	BE	SPB, CB	BE	SPB, CB	BE	SPB, CB	
mm <sup>2</sup>	kA/sec	A										
1x50RMC/16	4.7	3.7	226	228	213	214	234	236	200	200		
1x70RMC/25	6.6	5.3	274	279	261	262	288	292	247	247		
1x95RMC/35	9.0	7.1	326	336	313	315	348	357	300	302		
1x120RMC/50	11.3	9.8	365	383	355	359	394	411	343	347		
1x150RMC/50	14.2	9.8	407	432	400	405	445	470	391	395		
1x185RMC/50	17.5	9.8	455	491	453	460	506	541	447	454		
1x240RMC/50	22.7	9.8	516	572	525	535	586	639	526	536		
1x300RMC/50	28.4	9.8	571	649	592	606	660	736	601	615		
1x400RMC/50	37.8	9.8	638	749	677	699	755	864	699	720		
1x500RMC/50	47.3	9.8	705	859	768	798	852	1007	808	838		
1x630RMC/50	59.5	9.8	778	987	871	913	960	1181	935	977		
1x800RMC/50	75.6	9.8	846	1123	975	1034	1064	1368	1065	1125		
1x1000RMC/50	94.5	9.8	915	1271	1078	1157	1175	1584	1206	1287		

## Operating Conditions

For laying in ground		For installation in air	
Depth of lay:	0,7 m.	Ambient temperature:	30°C
Ground temperature:	20°C	Protection from direct solar radiation	
Soil thermal resistivity:	1/ 2,5 K · m/W		

# MEDIUM VOLTAGE XLPE POWER CABLES – Longitudinally and Radially Sealed

## 8.7/15 (17.5) kV

COPPER CONDUCTOR - Round, stranded and compacted conductor - Class 2  
2XS(FL)2Y acc. to IEC 60502-2:2005 and BS 6622:2007  
XRUHKXS acc. ZN-TF-501:2002

25

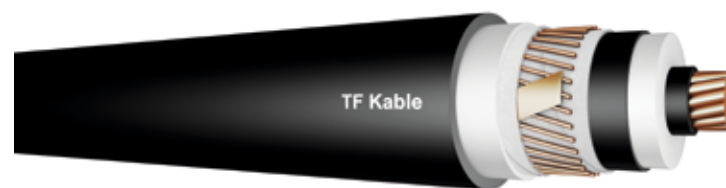

Conductor – nominal cross sectional area	Conductor diameter	Insulation		Metallic screen		Cable diameter $D_e$	Cable weight	Maximum cable pulling force	Recommended min. bending radius for laying
		Thickness	Diameter over insulation	Cross sectional area	Diameter over metallic screen				
mm <sup>2</sup>	mm			mm <sup>2</sup>	mm	mm	kg/km	kN	m
1x35RMC	7.0 <sup>+0.15</sup>	4.5	17.2	16	21.3	27.3	920	1.75	0.57
1x50RMC	8.25 <sup>+0.20</sup>	4.5	18.5	16	22.5	28.6	1060	2.5	0.60
1x70RMC	9.6 <sup>+0.20</sup>	4.5	19.8	25	23.9	29.9	1370	3.5	0.63
1x95RMC	11.5 <sup>+0.20</sup>	4.5	21.7	35	25.8	31.8	1740	4.75	0.68
1x120RMC	12.9 <sup>+0.25</sup>	4.5	23.1	50	27.2	33.2	2140	6	0.72
1x150RMC	14.5 <sup>+0.30</sup>	4.5	24.7	50	28.8	34.8	2420	7.5	0.76
1x185RMC	16.0 <sup>+0.30</sup>	4.5	26.2	50	30.3	36.3	2780	9.25	0.79
1x240RMC	18.5 <sup>+0.30</sup>	4.5	28.7	50	32.8	38.8	3340	12	0.86
1x300RMC	20.5 <sup>+0.30</sup>	4.5	30.7	50	34.8	40.8	3930	15	0.91
1x400RMC	23.5 <sup>+0.30</sup>	4.5	33.7	50	37.8	43.8	4800	20	0.98
1x500RMC	26.5 <sup>+0.40</sup>	4.5	37.2	50	41.5	47.5	5910	25	1.07
1x630RMC	30.3 <sup>+0.40</sup>	4.5	41.3	50	45.5	51.8	7270	31.5	1.18
1x800RMC	34.6 <sup>+0.50</sup>	4.5	46.0	50	50.2	56.9	8970	40	1.30
1x1000RMC	38.2 <sup>+0.40</sup>	4.5	49.6	50	53.8	60.7	10880	50	1.38

# Electrical data

RM (RMC) - Round Multiwire Conductor IC (C - compacted), Class 2

SPB - Single Point Bonded

CB - Cross Bonded

BE - Both Ends

$D_e$  - Cable diameter

2 - Cables in trefoil formation, the distance between cables  $D_e$

3 - Cables in flat formation (in the ground) – the distance between cables  $D_e + 70$  mm

4 - Cables in flat formation (in the air) – the distance between cables  $2 \times D_e$

Nominal cross sectional area	Conductor resistance		Metallic screen resistance		Electrical field stress at conductor/insulation	Zero resistance $R_0$	Zero reactance $X_0$	Capacitance $C$	Capacitive reactance $X_c$	Charging current $I_c$	Inductance $L$	Inductive reactance $X_l$	Impedance
	DC 20°C	AC 90°C	DC 20°C	AC 80°C							$0^0 0^2$	$0^0 0^2$	$0^0 0^2$
Conductor/Metallic screen	DC 20°C	AC 90°C	DC 20°C	AC 80°C							$000^3$	$000^3$	$000^3$
											$000^4$	$000^4$	$000^4$
mm <sup>2</sup>	Ω/km				kV/mm	Ω/km	Ω/km	μF/km	kΩ/km	A/km	mH/km	Ω/km	Ω/km
1x35RMC/16	0.524	0.668	1.12	1.38	2.84/1.32	1.48	0.085	0.17	19.1	0.46	0.46	0.145	0.684
											0.76	0.239	0.710
											0.65	0.203	0.698
1x50RMC/16	0.387	0.494	1.12	1.38	2.72/1.37	1.30	0.078	0.19	17.2	0.51	0.44	0.137	0.512
											0.73	0.230	0.544
											0.62	0.195	0.531
1x70RMC/25	0.268	0.342	0.72	0.89	2.63/1.41	0.94	0.072	0.20	15.6	0.56	0.42	0.131	0.366
											0.70	0.221	0.407
											0.60	0.189	0.391
1x95RMC/35	0.193	0.247	0.51	0.63	2.52/1.45	0.71	0.066	0.23	13.7	0.63	0.39	0.123	0.276
											0.67	0.211	0.324
											0.58	0.181	0.306
1x120RMC/50	0.153	0.196	0.36	0.44	2.46/1.48	0.55	0.062	0.25	12.7	0.69	0.38	0.119	0.229
											0.65	0.204	0.283
											0.56	0.177	0.264
1x150RMC/50	0.124	0.159	0.36	0.44	2.41/1.51	0.51	0.058	0.27	11.6	0.75	0.36	0.114	0.196
											0.63	0.198	0.254
											0.55	0.172	0.234
1x185RMC/50	0.0991	0.128	0.36	0.44	2.37/1.54	0.47	0.055	0.30	10.8	0.81	0.35	0.111	0.169
											0.61	0.193	0.231
											0.54	0.169	0.212
1x240RMC/50	0.0754	0.0978	0.36	0.44	2.31/1.57	0.43	0.051	0.33	9.6	0.90	0.34	0.106	0.144
											0.59	0.185	0.209
											0.52	0.164	0.191
1x300RMC/50	0.0601	0.0789	0.36	0.44	2.27/1.59	0.41	0.048	0.36	8.9	0.98	0.33	0.103	0.129
											0.57	0.180	0.196
											0.51	0.161	0.179
1x400RMC/50	0.0470	0.0629	0.36	0.44	2.23/1.62	0.39	0.045	0.40	7.9	1.10	0.31	0.098	0.117
											0.55	0.173	0.184
											0.50	0.156	0.169
1x500RMC/50	0.0366	0.0505	0.36	0.44	2.17/1.63	0.37	0.043	0.44	7.2	1.21	0.31	0.096	0.108
											0.53	0.167	0.175
											0.49	0.154	0.162
1x630RMC/50	0.0283	0.0410	0.36	0.44	2.13/1.65	0.35	0.041	0.50	6.4	1.37	0.30	0.093	0.102
											0.51	0.161	0.166
											0.48	0.151	0.156

Nominal cross sectional area	Conductor resistance		Metallic screen resistance		Electrical field stress at conductor/insulation	Zero resistance $R_0$	Zero reactance $X_0$	Capacitance $C$	Capacitive reactance $X_c$	Charging current $I_c$	Inductance $L$	Inductive reactance $X_L$	Impedance
	DC 20°C	AC 90°C	DC 20°C	AC 80°C									
Conductor/ Metallic screen	DC 20°C	AC 90°C	DC 20°C	AC 80°C									
mm <sup>2</sup>	Ω/km				kV/mm	Ω/km	Ω/km	μF/km	kΩ/km	A/km	mH/km	Ω/km	Ω/km
1x800RMC/50											0.29	0.091	0.097
											0.49	0.155	0.159
											0.47	0.149	0.152
1x1000RMC/50											0.28	0.088	0.093
											0.48	0.151	0.154
											0.47	0.146	0.149

## Current – carrying capacity

Nominal cross sectional area	Max short circuit capacity	GROUND				AIR						
				FLAT		TREFOIL		FLAT		TREFOIL		
		Conductor	Metallic screen	BE	SPB, CB	BE	SPB, CB	BE	SPB, CB	BE	SPB, CB	
mm <sup>2</sup>	kA/sec	A										
1x35RMC/16	5.0	3.7	244	247	232	233	251	253	215	215		
1x50RMC/16	7.2	3.7	289	294	275	276	300	304	258	258		
1x70RMC/25	10.0	5.3	350	360	336	338	368	377	318	319		
1x95RMC/35	13.6	7.1	413	435	404	408	443	463	387	391		
1x120RMC/50	17.2	9.8	455	496	457	465	498	534	443	449		
1x150RMC/50	21.5	9.8	502	560	513	523	559	610	503	512		
1x185RMC/50	26.5	9.8	555	634	577	592	627	698	572	585		
1x240RMC/50	34.3	9.8	624	740	667	689	723	830	672	693		
1x300RMC/50	42.9	9.8	682	838	749	779	805	952	764	793		
1x400RMC/50	57.2	9.8	749	962	848	890	905	1113	880	921		
1x500RMC/50	71.5	9.8	816	1097	951	1009	1008	1291	1006	1062		
1x630RMC/50	90.1	9.8	887	1252	1062	1140	1117	1504	1146	1225		
1x800RMC/50	114.4	9.8	951	1412	1165	1269	1220	1731	1288	1393		
1x1000RMC/50	143.0	9.8	1003	1562	1257	1387	1306	1946	1411	1545		

## Operating Conditions

For laying in ground		For installation in air	
Depth of lay:	0,7 m.	Ambient temperature:	30°C
Ground temperature:	20°C	Protection from direct solar radiation	
Soil thermal resistivity:	1/ 2,5 K · m/W		

# MEDIUM VOLTAGE XLPE POWER CABLES

## 12/20 (24) kV

ALUMINIUM CONDUCTOR - Round, stranded and compacted conductor - Class 2  
 NA2XSY acc. to DIN VDE 0276-620 and HD 62052:2010 part 10 section C  
 A2XSY acc. to IEC 60502-2:2005 and BS 6622:2007  
 YHAKXS acc. to ZN-TF-501:2002

28

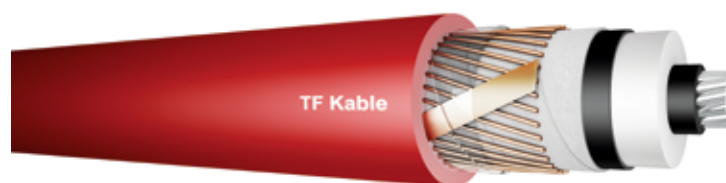

Conductor – nominal cross sectional area	Conductor diameter	Insulation		Metallic screen		Cable diameter D <sub>e</sub>	Cable weight	Maximum cable pulling force	Recommended min. bending radius for laying
		Thickness	Diameter over insulation	Cross sectional area	Diameter over metallic screen				
mm <sup>2</sup>	mm			mm <sup>2</sup>	mm	mm	kg/km	kN	m
1x50RMC	8.25 <sup>+0.10</sup>	5.5	20.5	16	24.4	29.1	860	1.5	0.44
1x70RMC	9.5 <sup>+0.20</sup>	5.5	21.7	25	25.6	30.4	1040	2.1	0.46
1x95RMC	11.3 <sup>+0.20</sup>	5.5	23.5	35	27.4	32.2	1260	2.85	0.48
1x120RMC	12.5 <sup>+0.20</sup>	5.5	24.7	50	28.6	33.4	1500	3.6	0.50
1x150RMC	14.2 <sup>+0.20</sup>	5.5	26.4	50	30.3	35.1	1620	4.5	0.53
1x185RMC	15.8 <sup>+0.20</sup>	5.5	28.0	50	31.9	36.7	1770	5.55	0.55
1x240RMC	17.9 <sup>+0.10</sup>	5.5	30.1	50	34.0	38.8	1980	7.2	0.58
1x300RMC	20.0 <sup>+0.30</sup>	5.5	32.2	50	36.1	40.9	2200	9	0.61
1x400RMC	22.9 <sup>+0.30</sup>	5.5	35.1	50	39.0	43.8	2510	12	0.66
1x500RMC	25.7 <sup>+0.40</sup>	5.5	38.4	50	42.5	47.3	2940	15	0.71
1x630RMC	29.3 <sup>+0.50</sup>	5.5	42.3	50	46.4	51.3	3460	18.9	0.77
1x800RMC	33.0 <sup>+0.50</sup>	5.5	46.4	50	50.5	55.8	4100	24	0.84
1x1000RMC	38.0 <sup>+0.50</sup>	5.5	51.4	50	55.5	61.0	4850	30	0.92

# Electrical data

RM (RMC) - Round Multiwire Conductor IC (C - compacted), Class 2  
 SPB - Single Point Bonded  
 CB - Cross Bonded  
 BE - Both Ends  
 D<sub>e</sub> - Cable diameter

2 - Cables in trefoil formation, the distance between cables D<sub>e</sub>  
 3 - Cables in flat formation (in the ground) – the distance between cables D<sub>e</sub> + 70 mm  
 4 - Cables in flat formation (in the air) – the distance between cables 2 x D<sub>e</sub>

Nominal cross sectional area	Conductor resistance		Metallic screen resistance		Electrical field stress at conductor/insulation	Zero resistance R <sub>0</sub>	Zero reactance X <sub>0</sub>	Capacitance C	Capacitive reactance X <sub>c</sub>	Charging current I <sub>c</sub>	Inductance L	Inductive reactance XI	Impedance
	DC 20°C	AC 90°C	DC 20°C	AC 80°C							o <sup>0</sup> o <sup>2</sup>	o <sup>0</sup> o <sup>2</sup>	o <sup>0</sup> o <sup>2</sup>
Conductor/ Metallic screen	DC 20°C	AC 90°C	DC 20°C	AC 80°C							ooo <sup>3</sup>	ooo <sup>3</sup>	ooo <sup>3</sup>
mm <sup>2</sup>	Ω/km				kV/mm	Ω/km	Ω/km	μF/km	kΩ/km	A/km	mH/km	Ω/km	Ω/km
1x50RMC/16	0.641	0.822	1.12	1.38	3.27/1.48	2.20	0.081	0.16	19.8	0.61	0.44	0.138	0.834
											0.73	0.230	0.854
											0.63	0.197	0.845
1x70RMC/25	0.443	0.568	0.72	0.89	3.15/1.52	1.45	0.075	0.18	18.1	0.66	0.42	0.132	0.583
											0.71	0.222	0.610
											0.61	0.190	0.599
1x95RMC/35	0.320	0.411	0.51	0.63	3.01/1.58	1.04	0.069	0.20	16.1	0.74	0.40	0.125	0.429
											0.68	0.212	0.462
											0.58	0.183	0.450
1x120RMC/50	0.253	0.325	0.36	0.44	2.94/1.61	0.77	0.065	0.21	15.0	0.80	0.39	0.121	0.347
											0.66	0.207	0.385
											0.57	0.179	0.371
1x150RMC/50	0.206	0.265	0.36	0.44	2.86/1.65	0.71	0.061	0.23	13.8	0.87	0.37	0.116	0.289
											0.64	0.200	0.331
											0.55	0.174	0.317
1x185RMC/50	0.164	0.211	0.36	0.44	2.80/1.68	0.65	0.058	0.25	12.7	0.94	0.36	0.112	0.239
											0.62	0.194	0.286
											0.54	0.170	0.271
1x240RMC/50	0.125	0.161	0.36	0.44	2.73/1.71	0.60	0.054	0.27	11.6	1.04	0.34	0.108	0.194
											0.60	0.187	0.247
											0.53	0.166	0.231
1x300RMC/50	0.100	0.130	0.36	0.44	2.67/1.74	0.57	0.051	0.30	10.6	1.13	0.33	0.104	0.166
											0.58	0.181	0.223
											0.52	0.162	0.208
1x400RMC/50	0.0778	0.102	0.36	0.44	2.61/1.78	0.54	0.047	0.33	9.6	1.25	0.32	0.100	0.143
											0.56	0.175	0.202
											0.50	0.158	0.188
1x500RMC/50	0.0605	0.0799	0.36	0.44	2.54/1.79	0.52	0.046	0.37	8.7	1.38	0.31	0.098	0.126
											0.54	0.169	0.187
											0.50	0.156	0.175

Nominal cross sectional area	Conductor resistance		Metallic screen resistance		Electrical field stress at conductor/insulation	Zero resistance $R_0$	Zero reactance $X_0$	Capacitance $C$	Capacitive reactance $X_c$	Charging current $I_c$	Inductance $L$	Inductive reactance $X_l$	Impedance
	DC 20°C	AC 90°C	DC 20°C	AC 80°C									
Conductor/ Metallic screen	DC 20°C	AC 90°C	DC 20°C	AC 80°C									
mm <sup>2</sup>	Ω/km				kV/mm	Ω/km	Ω/km	μF/km	kΩ/km	A/km	mH/km	Ω/km	Ω/km
1x630RMC/50	0.0469	0.0633	0.36	0.44	2.49/1.83	0.51	0.043	0.41	7.7	1.55	0.30	0.094	0.114
											0.52	0.163	0.175
											0.49	0.153	0.165
											0.29	0.092	0.105
1x800RMC/50	0.0367	0.0511	0.36	0.44	2.45/1.85	0.49	0.041	0.46	7.0	1.73	0.50	0.158	0.166
											0.48	0.150	0.159
											0.28	0.089	0.099
1x1000RMC/50	0.0291	0.0425	0.36	0.44	2.41/1.88	0.48	0.038	0.51	6.2	1.94	0.48	0.152	0.157
											0.47	0.147	0.153

## Current – carrying capacity

Nominal cross sectional area	Max short circuit capacity	GROUND				AIR				
		FLAT		TREFOIL		FLAT		TREFOIL		
		Conductor	Metallic screen	BE	SPB, CB	BE	SPB, CB	BE	SPB, CB	BE
mm <sup>2</sup>	kA/sec	A								
1x50RMC/16	4.7	3.7	222	224	211	211	230	231	197	197
1x70RMC/25	6.6	5.3	271	274	257	258	283	286	243	244
1x95RMC/35	9.0	7.1	323	330	309	310	342	349	296	297
1x120RMC/50	11.3	9.8	362	376	351	354	388	402	339	342
1x150RMC/50	14.2	9.8	405	425	396	399	440	459	386	389
1x185RMC/50	17.5	9.8	455	483	448	453	501	528	442	447
1x240RMC/50	22.7	9.8	519	563	520	528	582	624	520	528
1x300RMC/50	28.4	9.8	578	639	588	599	659	719	595	606
1x400RMC/50	37.8	9.8	650	738	674	690	758	844	694	710
1x500RMC/50	47.3	9.8	726	846	769	791	862	985	805	826
1x630RMC/50	59.5	9.8	810	974	875	907	982	1154	933	964
1x800RMC/50	75.6	9.8	890	1109	982	1026	1098	1336	1067	1111
1x1000RMC/50	94.5	9.8	975	1256	1093	1152	1226	1547	1213	1272

## Operating Conditions

For laying in ground		For installation in air	
Depth of lay:	0,7 m.	Ambient temperature:	30°C
Ground temperature:	20°C	Protection from direct solar radiation	
Soil thermal resistivity:	1/ 2,5 K · m/W		

# MEDIUM VOLTAGE XLPE POWER CABLES

## 12/20 (24) kV

COPPER CONDUCTOR - Round, stranded and compacted conductor - Class 2  
 N2XSY acc. to DIN VDE 0276-620 and HD 620S2:2010 part 10 section C  
 2XSY acc. to IEC 60502-2:2005 and BS 6622:2007  
 YHKXS acc. to ZN-TF-501:2002

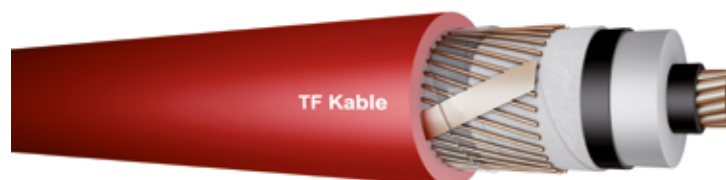

Conductor – nominal cross sectional area	Conductor diameter	Insulation		Metallic screen		Cable diameter D <sub>e</sub>	Cable weight	Maximum cable pulling force	Recommended min. bending radius for laying
		Thickness	Diameter over insulation	Cross sectional area	Diameter over metallic screen				
mm <sup>2</sup>	mm			mm <sup>2</sup>	mm	mm	kg/km	kN	m
1x35RMC	7.0 <sup>+0.15</sup>	5.5	19.2	16	23.1	27.9	990	1.75	0.42
1x50RMC	8.25 <sup>+0.20</sup>	5.5	20.5	16	24.4	29.1	1140	2.5	0.44
1x70RMC	9.6 <sup>+0.20</sup>	5.5	21.8	25	25.7	30.5	1450	3.5	0.46
1x95RMC	11.5 <sup>+0.20</sup>	5.5	23.7	35	27.6	32.4	1830	4.75	0.49
1x120RMC	12.9 <sup>+0.25</sup>	5.5	25.1	50	29.0	33.8	2230	6	0.51
1x150RMC	14.5 <sup>+0.30</sup>	5.5	26.7	50	30.6	35.4	2520	7.5	0.53
1x185RMC	16.0 <sup>+0.30</sup>	5.5	28.2	50	32.1	36.9	2890	9.25	0.55
1x240RMC	18.5 <sup>+0.30</sup>	5.5	30.7	50	34.6	39.4	3460	12	0.59
1x300RMC	20.5 <sup>+0.30</sup>	5.5	32.7	50	36.6	41.4	4060	15	0.62
1x400RMC	23.5 <sup>+0.30</sup>	5.5	35.7	50	39.6	44.4	4940	20	0.67
1x500RMC	26.5 <sup>+0.40</sup>	5.5	39.2	50	43.3	48.1	6050	25	0.72
1x630RMC	30.3 <sup>+0.40</sup>	5.5	43.3	50	47.4	52.5	7460	31.5	0.79
1x800RMC	34.6 <sup>+0.50</sup>	5.5	48.0	50	52.1	57.4	9170	40	0.86
1x1000RMC	38.2 <sup>+0.40</sup>	5.5	51.6	50	55.7	61.4	11130	50	0.92

# Electrical data

RM (RMC) - Round Multiwire Conductor IC (C - compacted), Class 2  
 SPB - Single Point Bonded  
 CB - Cross Bonded  
 BE - Both Ends  
 D<sub>e</sub> - Cable diameter

2 - Cables in trefoil formation, the distance between cables D<sub>e</sub>  
 3 - Cables in flat formation (in the ground) – the distance between cables D<sub>e</sub> + 70 mm  
 4 - Cables in flat formation (in the air) – the distance between cables 2 x D<sub>e</sub>

Nominal cross sectional area	Conductor resistance		Metallic screen resistance		Electrical field stress at conductor/insulation	Zero resistance R <sub>0</sub>	Zero reactance X <sub>0</sub>	Capacitance C	Capacitive reactance X <sub>c</sub>	Charging current I <sub>c</sub>	Inductance L	Inductive reactance XI	Impedance
	DC 20°C	AC 90°C	DC 20°C	AC 80°C							0 <sup>0</sup> 0 <sup>2</sup>	0 <sup>0</sup> 0 <sup>2</sup>	0 <sup>0</sup> 0 <sup>2</sup>
Conductor/Metallic screen											000 <sup>3</sup>	000 <sup>3</sup>	000 <sup>3</sup>
mm <sup>2</sup>	Ω/km				kV/mm	Ω/km	Ω/km	μF/km	kΩ/km	A/km	mH/km	Ω/km	Ω/km
1x35RMC/16											0.47	0.146	0.684
											0.76	0.240	0.710
											0.65	0.204	0.699
1x50RMC/16											0.44	0.138	0.513
											0.73	0.230	0.545
											0.63	0.197	0.531
1x70RMC/25											0.42	0.132	0.367
											0.70	0.221	0.407
											0.60	0.190	0.391
1x95RMC/35											0.40	0.124	0.276
											0.67	0.211	0.325
											0.58	0.182	0.307
1x120RMC/50											0.38	0.120	0.230
											0.65	0.205	0.283
											0.57	0.178	0.265
1x150RMC/50											0.37	0.115	0.196
											0.63	0.198	0.254
											0.55	0.173	0.235
1x185RMC/50											0.36	0.112	0.170
											0.61	0.193	0.231
											0.54	0.170	0.212
1x240RMC/50											0.34	0.107	0.145
											0.59	0.185	0.210
											0.52	0.165	0.192
1x300RMC/50											0.33	0.103	0.130
											0.57	0.180	0.197
											0.51	0.161	0.180
1x400RMC/50											0.32	0.099	0.117
											0.55	0.173	0.184
											0.50	0.157	0.169
1x500RMC/50											0.31	0.097	0.109
											0.53	0.168	0.175
											0.49	0.155	0.163

Nominal cross sectional area	Conductor resistance		Metallic screen resistance		Electrical field stress at conductor/insulation	Zero resistance $R_0$	Zero reactance $X_0$	Capacitance $C$	Capacitive reactance $X_c$	Charging current $I_c$	Inductance $L$	Inductive reactance $X_L$	Impedance
	DC 20°C	AC 90°C	DC 20°C	AC 80°C									
Conductor/ Metallic screen	DC 20°C	AC 90°C	DC 20°C	AC 80°C									
mm <sup>2</sup>	Ω/km				kV/mm	Ω/km	Ω/km	μF/km	kΩ/km	A/km	mH/km	Ω/km	Ω/km
1x630RMC/50											0.30	0.094	0.102
	0.0283	0.0409	0.36	0.44	2.48/1.83	0.48	0.042	0.42	7.5	1.59	0.51	0.162	0.167
											0.48	0.152	0.157
1x800RMC/50											0.29	0.091	0.097
	0.0221	0.0341	0.36	0.44	2.44/1.86	0.48	0.040	0.48	6.7	1.79	0.50	0.156	0.159
											0.47	0.149	0.153
1x1000RMC/50											0.25	0.089	0.094
	0.0176	0.0294	0.36	0.44	2.41/1.88	0.47	0.038	0.52	6.2	1.95	0.48	0.151	0.154
											0.47	0.147	0.150

## Current – carrying capacity

Nominal cross sectional area	Max short circuit capacity	GROUND				AIR					
				FLAT		TREFOIL		FLAT		TREFOIL	
		Conductor	Metallic screen	BE	SPB, CB	BE	SPB, CB	BE	SPB, CB	BE	SPB, CB
mm <sup>2</sup>	kA/sec	A									
1x35RMC/16	5.0	3.7	241	243	229	229	246	248	212	212	
1x50RMC/16	7.2	3.7	286	289	272	272	295	298	254	255	
1x70RMC/25	10.0	5.3	346	354	332	333	363	369	314	315	
1x95RMC/35	13.6	7.1	411	427	399	401	438	452	382	385	
1x120RMC/50	17.2	9.8	455	487	452	458	493	522	438	443	
1x150RMC/50	21.5	9.8	505	550	508	516	555	596	498	505	
1x185RMC/50	26.5	9.8	560	623	573	584	626	682	567	577	
1x240RMC/50	34.3	9.8	635	728	665	682	725	811	668	683	
1x300RMC/50	42.9	9.8	699	825	748	771	813	931	760	782	
1x400RMC/50	57.2	9.8	775	947	849	881	922	1088	878	909	
1x500RMC/50	71.5	9.8	854	1082	957	1000	1036	1263	1007	1050	
1x630RMC/50	90.1	9.8	938	1235	1071	1131	1159	1469	1152	1211	
1x800RMC/50	114.4	9.8	1020	1395	1187	1265	1282	1693	1300	1379	
1x1000RMC/50	143.0	9.8	1086	1545	1285	1384	1382	1902	1430	1530	

## Operating Conditions

For laying in ground		For installation in air	
Depth of lay:	0,7 m.	Ambient temperature:	30°C
Ground temperature:	20°C	Protection from direct solar radiation	
Soil thermal resistivity:	1/ 2,5 K · m/W		

# MEDIUM VOLTAGE XLPE POWER CABLES – Longitudinally Sealed

## 12/20 (24) kV

ALUMINIUM CONDUCTOR - Round, stranded and compacted conductor - Class 2  
NA2XS(F)2Y acc. to DIN VDE 0276-620 and HD 620S2:2010 part 10 section C  
A2XS(F)2Y acc. to IEC 60502-2:2005 and BS 6622:2007  
XUHAKXS acc. ZN-TF-501:2002

34



Conductor – nominal cross sectional area	Conductor diameter	Insulation		Metallic screen		Cable diameter D <sub>e</sub>	Cable weight	Maximum cable pulling force	Recommended min. bending radius for laying
		Thickness	Diameter over insulation	Cross sectional area	Diameter over metallic screen				
mm <sup>2</sup>	mm			mm <sup>2</sup>	mm	mm	kg/km	kN	m
1x50RMC	8.25 <sup>+0.10</sup>	5.5	20.5	16	24.6	30.1	790	1.5	0.45
1x70RMC	9.5 <sup>+0.20</sup>	5.5	21.7	25	25.8	31.4	970	2.1	0.47
1x95RMC	11.3 <sup>+0.20</sup>	5.5	23.5	35	27.6	33.2	1180	2.85	0.50
1x120RMC	12.5 <sup>+0.20</sup>	5.5	24.7	50	28.8	34.4	1420	3.6	0.52
1x150RMC	14.2 <sup>+0.20</sup>	5.5	26.4	50	30.5	36.1	1540	4.5	0.54
1x185RMC	15.8 <sup>+0.20</sup>	5.5	28.0	50	32.1	37.7	1680	5.55	0.57
1x240RMC	17.9 <sup>+0.10</sup>	5.5	30.1	50	34.2	39.8	1890	7.2	0.60
1x300RMC	20.0 <sup>+0.30</sup>	5.5	32.2	50	36.3	41.9	2110	9	0.63
1x400RMC	22.9 <sup>+0.30</sup>	5.5	35.1	50	39.2	44.8	2420	12	0.67
1x500RMC	25.7 <sup>+0.40</sup>	5.5	38.4	50	42.7	48.3	2840	15	0.72
1x630RMC	29.3 <sup>+0.50</sup>	5.5	42.3	50	46.6	52.3	3330	18.9	0.78
1x800RMC	33.0 <sup>+0.50</sup>	5.5	46.4	50	50.7	56.8	3950	24	0.85
1x1000RMC	38.0 <sup>+0.50</sup>	5.5	51.4	50	55.7	62.0	4680	30	0.93
1x1000RMC	38.2 <sup>+0.40</sup>	5.5	51.6	50	55.7	61.4	11130	50	0.92

# Electrical data

RM (RMC) - Round Multiwire Conductor IC (C - compacted), Class 2  
 SPB - Single Point Bonded  
 CB - Cross Bonded  
 BE - Both Ends  
 D<sub>e</sub> - Cable diameter

2 - Cables in trefoil formation, the distance between cables D<sub>e</sub>  
 3 - Cables in flat formation (in the ground) – the distance between cables D<sub>e</sub> + 70 mm  
 4 - Cables in flat formation (in the air) – the distance between cables 2 x D<sub>e</sub>

Nominal cross sectional area	Conductor resistance		Metallic screen resistance		Electrical field stress at conductor/insulation	Zero resistance R <sub>0</sub>	Zero reactance X <sub>0</sub>	Capacitance C	Capacitive reactance X <sub>c</sub>	Charging current I <sub>c</sub>	Inductance L	Inductive reactance XI	Impedance
	DC 20°C	AC 90°C	DC 20°C	AC 80°C							0 <sup>0</sup> 0 <sup>2</sup>	0 <sup>0</sup> 0 <sup>2</sup>	0 <sup>0</sup> 0 <sup>2</sup>
Conductor/ Metallic screen	DC 20°C	AC 90°C	DC 20°C	AC 80°C							000 <sup>3</sup>	000 <sup>3</sup>	000 <sup>3</sup>
mm <sup>2</sup>	Ω/km				kV/mm	Ω/km	Ω/km	μF/km	kΩ/km	A/km	mH/km	Ω/km	Ω/km
1x50RMC/16	0.641	0.822	1.12	1.38	3.27/1.48	2.20	0.081	0.16	19.8	0.61	0.45	0.141	0.834
											0.73	0.231	0.854
											0.63	0.199	0.846
1x70RMC/25	0.443	0.568	0.72	0.89	3.15/1.52	1.45	0.076	0.18	18.1	0.66	0.43	0.134	0.584
											0.71	0.223	0.610
											0.61	0.192	0.600
1x95RMC/35	0.320	0.411	0.51	0.63	3.01/1.58	1.04	0.069	0.20	16.1	0.74	0.40	0.127	0.430
											0.68	0.213	0.462
											0.59	0.185	0.450
1x120RMC/50	0.253	0.325	0.36	0.44	2.94/1.61	0.77	0.066	0.21	15.0	0.80	0.39	0.123	0.347
											0.66	0.207	0.385
											0.58	0.181	0.372
1x150RMC/50	0.206	0.265	0.36	0.44	2.86/1.65	0.71	0.061	0.23	13.8	0.87	0.38	0.118	0.290
											0.64	0.200	0.332
											0.56	0.176	0.318
1x185RMC/50	0.164	0.211	0.36	0.44	2.80/1.68	0.65	0.058	0.25	12.7	0.94	0.36	0.114	0.240
											0.62	0.194	0.287
											0.55	0.172	0.272
1x240RMC/50	0.125	0.161	0.36	0.44	2.73/1.71	0.60	0.054	0.27	11.6	1.04	0.35	0.109	0.195
											0.60	0.188	0.247
											0.53	0.168	0.233
1x300RMC/50	0.100	0.129	0.36	0.44	2.67/1.74	0.57	0.051	0.30	10.6	1.13	0.34	0.106	0.167
											0.58	0.182	0.223
											0.52	0.164	0.209
1x400RMC/50	0.0778	0.101	0.36	0.44	2.61/1.78	0.54	0.048	0.33	9.6	1.25	0.32	0.101	0.143
											0.56	0.175	0.202
											0.51	0.159	0.189
1x500RMC/50	0.0605	0.0799	0.36	0.44	2.54/1.79	0.52	0.046	0.37	8.7	1.38	0.31	0.099	0.127
											0.54	0.170	0.188
											0.50	0.157	0.176
1x630RMC/50	0.0469	0.0632	0.36	0.44	2.49/1.83	0.51	0.043	0.41	7.7	1.55	0.30	0.096	0.115
											0.52	0.164	0.175
											0.49	0.154	0.166

Nominal cross sectional area	Conductor resistance		Metallic screen resistance		Electrical field stress at conductor/insulation	Zero resistance $R_0$	Zero reactance $X_0$	Capacitance $C$	Capacitive reactance $X_c$	Charging current $I_c$	Inductance $L$	Inductive reactance $X_l$	Impedance
	DC 20°C	AC 90°C	DC 20°C	AC 80°C									
Conductor/ Metallic screen	DC 20°C	AC 90°C	DC 20°C	AC 80°C							$10^{-6} \text{ s}^2$	$10^{-6} \text{ s}^2$	$10^{-6} \text{ s}^2$
mm <sup>2</sup>	Ω/km				kV/mm	Ω/km	Ω/km	μF/km	kΩ/km	A/km	mH/km	Ω/km	Ω/km
1x800RMC/50	0.0367	0.0510	0.36	0.44	2.45/1.85	0.49	0.041	0.46	7.0	1.73	0.30	0.093	0.106
											0.48	0.151	0.166
											0.29	0.090	0.099
1x1000RMC/50	0.0291	0.0424	0.36	0.44	2.41/1.88	0.48	0.038	0.51	6.2	1.94	0.48	0.152	0.158
											0.47	0.148	0.154

## Current – carrying capacity

Nominal cross sectional area	Max short circuit capacity	GROUND				AIR						
		FLAT		TREFOIL		FLAT		TREFOIL				
		Conductor	Metallic screen	BE	SPB, CB	BE	SPB, CB	BE	SPB, CB	BE	SPB, CB	
mm <sup>2</sup>	kA/sec	A										
1x50RMC/16	4.7	3.7	225	226	213	213	233	234	200	200		
1x70RMC/25	6.6	5.3	274	278	260	261	287	290	246	247		
1x95RMC/35	9.0	7.1	327	334	313	314	348	355	300	301		
1x120RMC/50	11.3	9.8	367	381	355	358	395	409	343	346		
1x150RMC/50	14.2	9.8	410	430	400	403	448	467	391	394		
1x185RMC/50	17.5	9.8	461	489	453	458	510	537	448	453		
1x240RMC/50	22.7	9.8	526	570	525	533	593	635	527	534		
1x300RMC/50	28.4	9.8	585	646	594	605	672	731	603	614		
1x400RMC/50	37.8	9.8	658	746	681	697	773	859	704	719		
1x500RMC/50	47.3	9.8	734	855	776	798	879	1002	815	837		
1x630RMC/50	59.5	9.8	819	984	883	915	1002	1175	946	977		
1x800RMC/50	75.6	9.8	901	1121	991	1035	1123	1362	1082	1126		
1x1000RMC/50	94.5	9.8	986	1269	1103	1162	1255	1578	1231	1290		

## Operating Conditions

For laying in ground		For installation in air	
Depth of lay:	0,7 m.	Ambient temperature:	30°C
Ground temperature:	20°C	Protection from direct solar radiation	
Soil thermal resistivity:	1/ 2,5 K · m/W		

# MEDIUM VOLTAGE XLPE POWER CABLES – Longitudinally Sealed

## 12/20 (24) kV

COPPER CONDUCTOR - Round, stranded and compacted conductor - Class 2  
N2XS(F)2Y acc. to DIN VDE 0276-620 and HD 620S2:2010 part 10 section C  
2XS(F)2Y acc. to IEC 60502-2:2005 and BS 6622:2007  
XUHKXS acc. ZN-TF-501:2002

37



Conductor – nominal cross sectional area	Conductor diameter	Insulation		Metallic screen		Cable diameter D <sub>e</sub>	Cable weight	Maximum cable pulling force	Recommended min. bending radius for laying
		Thickness	Diameter over insulation	Cross sectional area	Diameter over metallic screen				
mm <sup>2</sup>	mm			mm <sup>2</sup>	mm	mm	kg/km	kN	m
1x35RMC	7.0 <sup>+0.15</sup>	5.5	19.2	16	23.3	28.9	930	1.75	0.43
1x50RMC	8.25 <sup>+0.20</sup>	5.5	20.5	16	24.6	30.1	1080	2.5	0.45
1x70RMC	9.6 <sup>+0.20</sup>	5.5	21.8	25	25.9	31.5	1380	3.5	0.47
1x95RMC	11.5 <sup>+0.20</sup>	5.5	23.7	35	27.8	33.4	1760	4.75	0.50
1x120RMC	12.9 <sup>+0.25</sup>	5.5	25.1	50	29.2	34.8	2150	6	0.52
1x150RMC	14.5 <sup>+0.30</sup>	5.5	26.7	50	30.8	36.4	2440	7.5	0.55
1x185RMC	16.0 <sup>+0.30</sup>	5.5	28.2	50	32.3	37.9	2800	9.25	0.57
1x240RMC	18.5 <sup>+0.30</sup>	5.5	30.7	50	34.8	40.4	3370	12	0.61
1x300RMC	20.5 <sup>+0.30</sup>	5.5	32.7	50	36.8	42.4	3960	15	0.64
1x400RMC	23.5 <sup>+0.30</sup>	5.5	35.7	50	39.8	45.4	4840	20	0.68
1x500RMC	26.5 <sup>+0.40</sup>	5.5	39.2	50	43.5	49.1	5940	25	0.74
1x630RMC	30.3 <sup>+0.40</sup>	5.5	43.3	50	47.6	53.5	7320	31.5	0.80
1x800RMC	34.6 <sup>+0.50</sup>	5.5	48.0	50	52.3	58.4	9020	40	0.88
1x1000RMC	38.2 <sup>+0.40</sup>	5.5	51.6	50	55.9	62.4	10940	50	0.94

# Electrical data

RM (RMC) - Round Multiwire Conductor IC (C - compacted), Class 2

SPB - Single Point Bonded

CB - Cross Bonded

BE - Both Ends

$D_e$  - Cable diameter

2 - Cables in trefoil formation, the distance between cables  $D_e$

3 - Cables in flat formation (in the ground) – the distance between cables  $D_e + 70$  mm

4 - Cables in flat formation (in the air) – the distance between cables  $2 \times D_e$

Nominal cross sectional area	Conductor resistance		Metallic screen resistance		Electrical field stress at conductor/insulation	Zero resistance $R_0$	Zero reactance $X_0$	Capacitance $C$	Capacitive reactance $X_c$	Charging current $I_c$	Inductance L	Inductive reactance $X_l$	Impedance
	DC 20°C	AC 90°C	DC 20°C	AC 80°C							$0^0 0^2$	$0^0 0^2$	$0^0 0^2$
Conductor/Metallic screen	DC 20°C	AC 90°C	DC 20°C	AC 80°C							$0^0 0^3$	$0^0 0^3$	$0^0 0^3$
mm <sup>2</sup>	Ω/km				kV/mm	Ω/km	Ω/km	μF/km	kΩ/km	A/km	mH/km	Ω/km	Ω/km
1x35RMC/16											0.47	0.148	0.685
											0.76	0.240	0.710
											0.66	0.206	0.699
1x50RMC/16											0.45	0.141	0.513
											0.73	0.231	0.545
											0.63	0.199	0.532
1x70RMC/25											0.43	0.134	0.367
											0.71	0.222	0.408
											0.61	0.192	0.392
1x95RMC/35											0.40	0.126	0.277
											0.67	0.212	0.325
											0.59	0.184	0.308
1x120RMC/50											0.39	0.122	0.230
											0.65	0.205	0.284
											0.57	0.180	0.266
1x150RMC/50											0.37	0.117	0.197
											0.63	0.199	0.255
											0.56	0.175	0.237
1x185RMC/50											0.36	0.113	0.171
											0.62	0.194	0.232
											0.55	0.172	0.214
1x240RMC/50											0.34	0.108	0.146
											0.59	0.186	0.210
											0.53	0.166	0.193
1x300RMC/50											0.33	0.105	0.131
											0.58	0.181	0.197
											0.52	0.163	0.181
1x400RMC/50											0.32	0.101	0.119
											0.55	0.174	0.185
											0.51	0.159	0.171
1x500RMC/50											0.31	0.098	0.110
											0.54	0.168	0.176
											0.50	0.156	0.164

Nominal cross sectional area	Conductor resistance		Metallic screen resistance		Electrical field stress at conductor/insulation	Zero resistance $R_0$	Zero reactance $X_0$	Capacitance $C$	Capacitive reactance $X_c$	Charging current $I_c$	Inductance $L$	Inductive reactance $X_l$	Impedance
	DC 20°C	AC 90°C	DC 20°C	AC 80°C									
Conductor/ Metallic screen	DC 20°C	AC 90°C	DC 20°C	AC 80°C									
mm <sup>2</sup>	Ω/km				kV/mm	Ω/km	Ω/km	μF/km	kΩ/km	A/km	mH/km	Ω/km	Ω/km
1x630RMC/50											0.30	0.095	0.103
											0.52	0.162	0.167
											0.49	0.153	0.158
1x800RMC/50											0.29	0.092	0.098
											0.50	0.156	0.160
											0.48	0.150	0.154
1x1000RMC/50											0.29	0.090	0.095
											0.48	0.152	0.155
											0.47	0.148	0.151

## Current – carrying capacity

Nominal cross sectional area	Max short circuit capacity	GROUND				AIR					
				FLAT		TREFOIL		FLAT		TREFOIL	
		Conductor	Metallic screen	BE	SPB, CB	BE	SPB, CB	BE	SPB, CB	BE	SPB, CB
mm <sup>2</sup>	kA/sec	A									
1x35RMC/16	5.0	3.7	244	246	231	231	250	252	215	215	
1x50RMC/16	7.2	3.7	289	292	275	275	300	303	257	258	
1x70RMC/25	10.0	5.3	351	358	335	337	369	375	318	319	
1x95RMC/35	13.6	7.1	416	432	403	406	445	460	387	390	
1x120RMC/50	17.2	9.8	461	493	457	463	502	531	443	449	
1x150RMC/50	21.5	9.8	511	556	514	522	566	606	504	511	
1x185RMC/50	26.5	9.8	567	631	579	590	638	694	574	584	
1x240RMC/50	34.3	9.8	643	736	672	689	740	825	677	692	
1x300RMC/50	42.9	9.8	708	834	756	779	829	947	770	792	
1x400RMC/50	57.2	9.8	785	958	857	889	940	1107	889	920	
1x500RMC/50	71.5	9.8	864	1093	965	1009	1057	1285	1020	1063	
1x630RMC/50	90.1	9.8	949	1249	1082	1142	1185	1496	1168	1227	
1x800RMC/50	114.4	9.8	1032	1410	1198	1277	1312	1725	1319	1398	
1x1000RMC/50	143.0	9.8	1100	1561	1297	1397	1417	1941	1452	1553	

## Operating Conditions

For laying in ground		For installation in air	
Depth of lay:	0,7 m.	Ambient temperature:	30°C
Ground temperature:	20°C	Protection from direct solar radiation	
Soil thermal resistivity:	1/ 2,5 K · m/W		

# MEDIUM VOLTAGE XLPE POWER CABLES – Longitudinally and Radially Sealed

## 12/20 (24) kV

40

ALUMINIUM CONDUCTOR - Round, stranded and compacted conductor - Class 2  
NA2XS(FL)2Y acc. to DIN VDE 0276-620 and HD 620S2:2010 part 10 section C  
A2XS(FL)2Y acc. to IEC 60502-2:2005 and BS 6622:2007  
XRUHAKXS acc. ZN-TF-501:2002

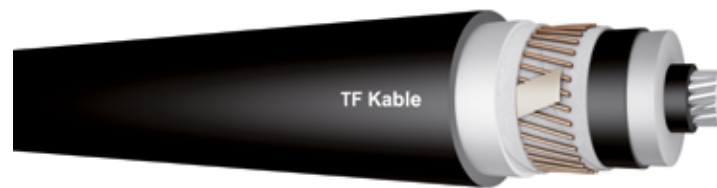

Conductor – nominal cross sectional area	Conductor diameter	Insulation		Metallic screen		Cable diameter D <sub>e</sub>	Cable weight	Maximum cable pulling force	Recommended min. bending radius for laying
		Thickness	Diameter over insulation	Cross sectional area	Diameter over metallic screen				
mm <sup>2</sup>	mm			mm <sup>2</sup>	mm	mm	kg/km	kN	m
1x50RMC	8.25 <sup>+0.10</sup>	5.5	20.5	16	24.5	30.6	860	1.5	0.65
1x70RMC	9.5 <sup>+0.20</sup>	5.5	21.7	25	25.8	31.8	1030	2.1	0.68
1x95RMC	11.3 <sup>+0.20</sup>	5.5	23.5	35	27.6	33.6	1250	2.85	0.73
1x120RMC	12.5 <sup>+0.20</sup>	5.5	24.7	50	28.8	34.8	1490	3.6	0.76
1x150RMC	14.2 <sup>+0.20</sup>	5.5	26.4	50	30.5	36.5	1610	4.5	0.80
1x185RMC	15.8 <sup>+0.20</sup>	5.5	28.0	50	32.1	38.1	1760	5.55	0.84
1x240RMC	17.9 <sup>+0.10</sup>	5.5	30.1	50	34.2	40.2	1970	7.2	0.89
1x300RMC	20.0 <sup>+0.30</sup>	5.5	32.2	50	36.3	42.3	2190	9	0.94
1x400RMC	22.9 <sup>+0.30</sup>	5.5	35.1	50	39.2	45.2	2500	12	1.02
1x500RMC	25.7 <sup>+0.40</sup>	5.5	38.4	50	42.7	48.7	2930	15	1.10
1x630RMC	29.3 <sup>+0.50</sup>	5.5	42.3	50	46.5	53.0	3450	18.9	1.20
1x800RMC	33.0 <sup>+0.50</sup>	5.5	46.4	50	50.6	57.3	4060	24	1.30
1x1000RMC	38.0 <sup>+0.50</sup>	5.5	51.4	50	55.6	62.7	4820	30	1.43

# Electrical data

RM (RMC) - Round Multiwire Conductor IC (C - compacted), Class 2

SPB - Single Point Bonded

CB - Cross Bonded

BE - Both Ends

D<sub>e</sub> - Cable diameter

2 - Cables in trefoil formation, the distance between cables D<sub>e</sub>

3 - Cables in flat formation (in the ground) – the distance between cables D<sub>e</sub> + 70 mm

4 - Cables in flat formation (in the air) – the distance between cables 2 x D<sub>e</sub>

Nominal cross sectional area	Conductor resistance		Metallic screen resistance		Electrical field stress at conductor/insulation	Zero resistance R <sub>0</sub>	Zero reactance X <sub>0</sub>	Capacitance C	Capacitive reactance X <sub>c</sub>	Charging current I <sub>c</sub>	Inductance L	Inductive reactance XI	Impedance
	DC 20°C	AC 90°C	DC 20°C	AC 80°C							0 <sup>0</sup> 0 <sup>2</sup>	0 <sup>0</sup> 0 <sup>2</sup>	0 <sup>0</sup> 0 <sup>2</sup>
Conductor/ Metallic screen	DC 20°C	AC 90°C	DC 20°C	AC 80°C							000 <sup>3</sup>	000 <sup>3</sup>	000 <sup>3</sup>
mm <sup>2</sup>	Ω/km				kV/mm	Ω/km	Ω/km	μF/km	kΩ/km	A/km	mH/km	Ω/km	Ω/km
1x50RMC/16	0.641	0.822	1.12	1.38	3.27/1.48	1.60	0.083	0.16	19.8	0.61	0.45	0.142	0.834
											0.74	0.231	0.854
											0.64	0.200	0.846
1x70RMC/25	0.443	0.568	0.72	0.89	3.15/1.52	1.16	0.078	0.18	18.1	0.66	0.43	0.135	0.584
											0.71	0.223	0.610
											0.62	0.193	0.600
1x95RMC/35	0.320	0.411	0.51	0.63	3.01/1.58	0.86	0.071	0.20	16.1	0.74	0.41	0.128	0.430
											0.68	0.213	0.463
											0.59	0.186	0.451
1x120RMC/50	0.253	0.325	0.36	0.44	2.94/1.61	0.67	0.067	0.21	15.0	0.80	0.39	0.124	0.347
											0.66	0.207	0.385
											0.58	0.182	0.372
1x150RMC/50	0.206	0.265	0.36	0.44	2.86/1.65	0.61	0.063	0.23	13.8	0.87	0.38	0.119	0.290
											0.64	0.200	0.332
											0.56	0.177	0.318
1x185RMC/50	0.164	0.211	0.36	0.44	2.80/1.68	0.55	0.060	0.25	12.7	0.94	0.36	0.115	0.240
											0.62	0.195	0.287
											0.55	0.173	0.273
1x240RMC/50	0.125	0.161	0.36	0.44	2.73/1.71	0.49	0.056	0.27	11.6	1.04	0.35	0.110	0.195
											0.60	0.188	0.248
											0.54	0.168	0.233
1x300RMC/50	0.100	0.129	0.36	0.44	2.67/1.74	0.46	0.053	0.30	10.6	1.13	0.34	0.106	0.168
											0.58	0.182	0.224
											0.52	0.164	0.209
1x400RMC/50	0.0778	0.101	0.36	0.44	2.61/1.78	0.43	0.049	0.33	9.6	1.25	0.32	0.102	0.144
											0.56	0.175	0.203
											0.51	0.160	0.190
1x500RMC/50	0.0605	0.0799	0.36	0.44	2.54/1.79	0.40	0.047	0.37	8.7	1.38	0.32	0.099	0.128
											0.54	0.170	0.188
											0.50	0.157	0.177

Nominal cross sectional area	Conductor resistance		Metallic screen resistance		Electrical field stress at conductor/insulation	Zero resistance $R_0$	Zero reactance $X_0$	Capacitance $C$	Capacitive reactance $X_c$	Charging current $I_c$	Inductance $L$	Inductive reactance $X_l$	Impedance
	DC 20°C	AC 90°C	DC 20°C	AC 80°C									
Conductor/ Metallic screen	DC 20°C	AC 90°C	DC 20°C	AC 80°C	kV/mm	$\Omega/km$	$\Omega/km$	$\mu F/km$	k $\Omega/km$	A/km	mH/km	$\Omega/km$	$\Omega/km$
mm <sup>2</sup>	$\Omega/km$												
1x630RMC/50											0.31	0.097	0.115
											0.52	0.164	0.176
											0.49	0.155	0.167
1x800RMC/50											0.30	0.094	0.107
											0.50	0.159	0.167
											0.48	0.152	0.160
1x1000RMC/50											0.29	0.091	0.100
											0.48	0.152	0.158
											0.47	0.149	0.155

## Current – carrying capacity

Nominal cross sectional area	Max short circuit capacity	GROUND				AIR				
		FLAT		TREFOIL		FLAT		TREFOIL		
		Conductor	Metallic screen	BE	SPB, CB	BE	SPB, CB	BE	SPB, CB	BE
mm <sup>2</sup>	kA/sec	A								
1x50RMC/16	4.7	3.7	224	226	212	213	233	235	201	201
1x70RMC/25	6.6	5.3	272	277	260	261	287	291	248	249
1x95RMC/35	9.0	7.1	324	334	312	314	347	356	301	303
1x120RMC/50	11.3	9.8	363	380	354	357	393	409	345	348
1x150RMC/50	14.2	9.8	405	429	398	403	444	467	392	397
1x185RMC/50	17.5	9.8	453	488	451	458	504	538	449	455
1x240RMC/50	22.7	9.8	515	568	523	533	585	635	527	537
1x300RMC/50	28.4	9.8	570	644	589	603	659	731	603	616
1x400RMC/50	37.8	9.8	637	744	675	696	753	858	701	721
1x500RMC/50	47.3	9.8	705	853	766	795	851	1000	810	838
1x630RMC/50	59.5	9.8	778	981	870	912	958	1171	936	977
1x800RMC/50	75.6	9.8	848	1117	974	1032	1063	1357	1067	1125
1x1000RMC/50	94.5	9.8	916	1264	1077	1155	1173	1570	1208	1287

## Operating Conditions

For laying in ground		For installation in air	
Depth of lay:	0,7 m.	Ambient temperature:	30°C
Ground temperature:	20°C	Protection from direct solar radiation	
Soil thermal resistivity:	1/ 2,5 K · m/W		

# MEDIUM VOLTAGE XLPE POWER CABLES – Longitudinally and Radially Sealed

## 12/20 (24) kV

COPPER CONDUCTOR - Round, stranded and compacted conductor - Class 2  
N2XS(FL)2Y acc. to DIN VDE 0276-620 and HD 620S2:2010 part 10 section C  
2XS(FL)2Y acc. to IEC 60502-2:2005 and BS 6622:2007  
XRUHKXS acc. ZN-TF-501:2002

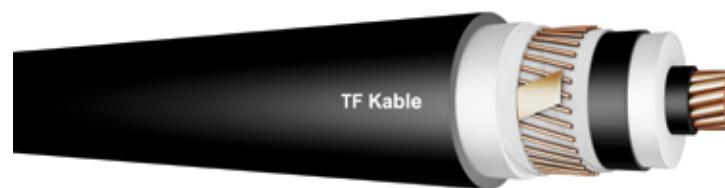

Conductor – nominal cross sectional area	Conductor diameter	Insulation		Metallic screen		Cable diameter $D_e$	Cable weight	Maximum cable pulling force	Recommended min. bending radius for laying
		Thickness	Diameter over insulation	Cross sectional area	Diameter over metallic screen				
mm <sup>2</sup>	mm			mm <sup>2</sup>	mm	mm	kg/km	kN	m
1x35RMC	7.0 <sup>+0.15</sup>	5.5	19.2	16	23.2	29.3	1000	1.75	0.62
1x50RMC	8.25 <sup>+0.20</sup>	5.5	20.5	16	24.5	30.6	1140	2.5	0.65
1x70RMC	9.6 <sup>+0.20</sup>	5.5	21.8	25	25.9	31.9	1450	3.5	0.68
1x95RMC	11.5 <sup>+0.20</sup>	5.5	23.7	35	27.8	33.8	1830	4.75	0.73
1x120RMC	12.9 <sup>+0.25</sup>	5.5	25.1	50	29.2	35.2	2230	6	0.77
1x150RMC	14.5 <sup>+0.30</sup>	5.5	26.7	50	30.8	36.8	2520	7.5	0.81
1x185RMC	16.0 <sup>+0.30</sup>	5.5	28.2	50	32.3	38.3	2890	9.25	0.84
1x240RMC	18.5 <sup>+0.30</sup>	5.5	30.7	50	34.8	40.8	3450	12	0.91
1x300RMC	20.5 <sup>+0.30</sup>	5.5	32.7	50	36.8	42.8	4050	15	0.96
1x400RMC	23.5 <sup>+0.30</sup>	5.5	35.7	50	39.8	45.8	4920	20	1.03
1x500RMC	26.5 <sup>+0.40</sup>	5.5	39.2	50	43.5	49.7	6060	25	1.12
1x630RMC	30.3 <sup>+0.40</sup>	5.5	43.3	50	47.5	54.0	7430	31.5	1.23
1x800RMC	34.6 <sup>+0.50</sup>	5.5	48.0	50	52.2	59.1	9150	40	1.34
1x1000RMC	38.2 <sup>+0.40</sup>	5.5	51.6	50	55.8	62.9	11070	50	1.43

# Electrical data

RM (RMC) - Round Multiwire Conductor IC (C - compacted), Class 2  
 SPB - Single Point Bonded  
 CB - Cross Bonded  
 BE - Both Ends  
 D<sub>e</sub> - Cable diameter

2 - Cables in trefoil formation, the distance between cables D<sub>e</sub>  
 3 - Cables in flat formation (in the ground) – the distance between cables D<sub>e</sub> + 70 mm  
 4 - Cables in flat formation (in the air) – the distance between cables 2 x D<sub>e</sub>

Nominal cross sectional area	Conductor resistance		Metallic screen resistance		Electrical field stress at conductor/insulation	Zero resistance R <sub>0</sub>	Zero reactance X <sub>0</sub>	Capacitance C	Capacitive reactance X <sub>c</sub>	Charging current I <sub>c</sub>	Inductance L	Inductive reactance XI	Impedance
	DC 20°C	AC 90°C	DC 20°C	AC 80°C							0 <sup>0</sup> 0 <sup>2</sup>	0 <sup>0</sup> 0 <sup>2</sup>	0 <sup>0</sup> 0 <sup>2</sup>
Conductor/Metallic screen											000 <sup>3</sup>	000 <sup>3</sup>	000 <sup>3</sup>
mm <sup>2</sup>	Ω/km				kV/mm	Ω/km	Ω/km	μF/km	kΩ/km	A/km	mH/km	Ω/km	Ω/km
1x35RMC/16	0.524	0.668	1.12	1.38	3.43/1.43	1.46	0.090	0.15	21.8	0.55	0.47	0.149	0.685
											0.77	0.240	0.710
											0.66	0.207	0.700
1x50RMC/16	0.387	0.494	1.12	1.38	3.27/1.48	1.27	0.083	0.16	19.8	0.61	0.45	0.142	0.514
											0.74	0.231	0.545
											0.64	0.200	0.533
1x70RMC/25	0.268	0.342	0.72	0.89	3.14/1.53	0.93	0.077	0.18	18.0	0.67	0.43	0.135	0.368
											0.71	0.222	0.408
											0.61	0.193	0.393
1x95RMC/35	0.193	0.247	0.51	0.63	3/1.58	0.70	0.070	0.20	15.9	0.75	0.40	0.127	0.277
											0.67	0.212	0.325
											0.59	0.185	0.308
1x120RMC/50	0.153	0.196	0.36	0.44	2.92/1.62	0.54	0.066	0.22	14.7	0.82	0.39	0.122	0.231
											0.65	0.206	0.284
											0.57	0.180	0.266
1x150RMC/50	0.124	0.159	0.36	0.44	2.85/1.65	0.50	0.062	0.23	13.5	0.89	0.37	0.118	0.198
											0.63	0.199	0.255
											0.56	0.176	0.237
1x185RMC/50	0.0991	0.128	0.36	0.44	2.79/1.68	0.47	0.059	0.25	12.6	0.95	0.36	0.114	0.171
											0.62	0.194	0.232
											0.55	0.172	0.214
1x240RMC/50	0.0754	0.0977	0.36	0.44	2.71/1.72	0.43	0.055	0.28	11.3	1.06	0.35	0.109	0.146
											0.59	0.186	0.210
											0.53	0.167	0.194
1x300RMC/50	0.0601	0.0787	0.36	0.44	2.66/1.75	0.41	0.052	0.30	10.4	1.15	0.34	0.106	0.132
											0.58	0.181	0.197
											0.52	0.164	0.182
1x400RMC/50	0.0470	0.0627	0.36	0.44	2.6/1.79	0.39	0.048	0.34	9.4	1.28	0.32	0.101	0.119
											0.55	0.174	0.185
											0.51	0.159	0.171
1x500RMC/50	0.0366	0.0503	0.36	0.44	2.53/1.8	0.37	0.046	0.38	8.5	1.42	0.31	0.099	0.111
											0.54	0.169	0.176
											0.50	0.157	0.165

Nominal cross sectional area	Conductor resistance		Metallic screen resistance		Electrical field stress at conductor/insulation	Zero resistance $R_0$	Zero reactance $X_0$	Capacitance $C$	Capacitive reactance $X_c$	Charging current $I_c$	Inductance $L$	Inductive reactance $X_l$	Impedance
	DC 20°C	AC 90°C	DC 20°C	AC 80°C									
Conductor/ Metallic screen	DC 20°C	AC 90°C	DC 20°C	AC 80°C									
mm <sup>2</sup>	Ω/km				kV/mm	Ω/km	Ω/km	μF/km	kΩ/km	A/km	mH/km	Ω/km	Ω/km
1x630RMC/50											0.30	0.096	0.104
											0.52	0.162	0.167
											0.49	0.154	0.159
1x800RMC/50											0.30	0.093	0.099
											0.50	0.157	0.160
											0.48	0.151	0.155
1x1000RMC/50											0.29	0.091	0.095
											0.48	0.152	0.155
											0.47	0.149	0.152

## Current – carrying capacity

Nominal cross sectional area	Max short circuit capacity	GROUND				AIR						
				FLAT		TREFOIL		FLAT		TREFOIL		
		Conductor	Metallic screen	BE	SPB, CB	BE	SPB, CB	BE	SPB, CB	BE	SPB, CB	
mm <sup>2</sup>	kA/sec	A										
1x35RMC/16	5.0	3.7	242	245	231	231	250	252	216	217		
1x50RMC/16	7.2	3.7	287	292	274	275	300	303	259	260		
1x70RMC/25	10.0	5.3	347	357	334	336	367	376	319	321		
1x95RMC/35	13.6	7.1	411	431	402	406	442	461	389	392		
1x120RMC/50	17.2	9.8	453	492	455	462	497	531	445	451		
1x150RMC/50	21.5	9.8	501	555	511	521	558	606	505	514		
1x185RMC/50	26.5	9.8	554	629	575	589	627	694	574	587		
1x240RMC/50	34.3	9.8	624	735	666	687	722	824	675	695		
1x300RMC/50	42.9	9.8	682	832	747	776	805	946	767	794		
1x400RMC/50	57.2	9.8	750	955	846	887	906	1105	883	922		
1x500RMC/50	71.5	9.8	818	1089	949	1006	1008	1281	1008	1064		
1x630RMC/50	90.1	9.8	889	1244	1060	1138	1117	1491	1150	1227		
1x800RMC/50	114.4	9.8	954	1403	1167	1271	1220	1716	1291	1395		
1x1000RMC/50	143.0	9.8	1006	1554	1257	1387	1305	1931	1415	1548		

## Operating Conditions

For laying in ground		For installation in air	
Depth of lay:	0,7 m.	Ambient temperature:	30°C
Ground temperature:	20°C	Protection from direct solar radiation	
Soil thermal resistivity:	1/ 2,5 K · m/W		

# MEDIUM VOLTAGE XLPE POWER CABLES

## 12/20 (24) kV

ALUMINIUM CONDUCTOR - Round, stranded and compacted conductor - Class 2  
 NA2XS<sub>Y</sub> acc. to DIN VDE 0276-620 and HD 620S2:2010 part 10 section C  
 A2XS<sub>Y</sub> acc. to IEC 60502-2:2005 and BS 6622:2007  
 YHAKXS acc. to ZN-TF-501:2002

46

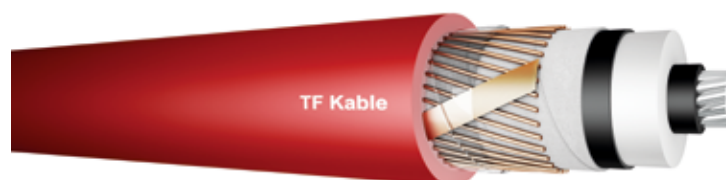

Conductor – nominal cross sectional area	Conductor diameter	Insulation		Metallic screen		Cable diameter D <sub>e</sub>	Cable weight	Maximum cable pulling force	Recommended min. bending radius for laying
		Thickness	Diameter over insulation	Cross sectional area	Diameter over metallic screen				
mm <sup>2</sup>	mm			mm <sup>2</sup>	mm	mm	kg/km	kN	m
1x50RMC	8.25 <sup>+0.10</sup>	8.0	25.5	16	29.4	34.1	1080	1.5	0.51
1x70RMC	9.5 <sup>+0.20</sup>	8.0	26.7	25	30.6	35.4	1270	2.1	0.53
1x95RMC	11.3 <sup>+0.20</sup>	8.0	28.5	35	32.4	37.2	1500	2.85	0.56
1x120RMC	12.5 <sup>+0.20</sup>	8.0	29.7	50	33.6	38.4	1750	3.6	0.58
1x150RMC	14.2 <sup>+0.20</sup>	8.0	31.4	50	35.3	40.1	1890	4.5	0.60
1x185RMC	15.8 <sup>+0.20</sup>	8.0	33.0	50	36.9	41.7	2050	5.55	0.63
1x240RMC	17.9 <sup>+0.10</sup>	8.0	35.1	50	39.0	43.8	2280	7.2	0.66
1x300RMC	20.0 <sup>+0.30</sup>	8.0	37.2	50	41.1	45.9	2510	9	0.69
1x400RMC	22.9 <sup>+0.30</sup>	8.0	40.1	50	44.0	48.8	2850	12	0.73
1x500RMC	25.7 <sup>+0.40</sup>	8.0	43.4	50	47.5	52.7	3350	15	0.79
1x630RMC	29.3 <sup>+0.50</sup>	8.0	47.3	50	51.4	56.7	3890	18.9	0.85
1x800RMC	33.0 <sup>+0.50</sup>	8.0	51.4	50	55.5	61.0	4550	24	0.92
1x1000RMC	38.0 <sup>+0.50</sup>	8.0	56.4	50	60.5	66.4	5370	30	1.00

# Electrical data

RM (RMC) - Round Multiwire Conductor IC (C - compacted), Class 2

SPB - Single Point Bonded

CB - Cross Bonded

BE - Both Ends

$D_e$  - Cable diameter

2 - Cables in trefoil formation, the distance between cables  $D_e$

3 - Cables in flat formation (in the ground) – the distance between cables  $D_e + 70$  mm

4 - Cables in flat formation (in the air) – the distance between cables  $2 \times D_e$

Nominal cross sectional area	Conductor resistance		Metallic screen resistance		Electrical field stress at conductor/insulation	Zero resistance $R_0$	Zero reactance $X_0$	Capacitance $C$	Capacitive reactance $X_c$	Charging current $I_c$	Inductance $L$	Inductive reactance $X_L$	Impedance
	DC 20°C	AC 90°C	DC 20°C	AC 80°C									
Conductor/ Metallic screen	DC 20°C	AC 90°C	DC 20°C	AC 80°C	kV/mm	$\Omega$ /km	$\Omega$ /km	$\mu$ F/km	k $\Omega$ /km	A/km	mH/km	$\Omega$ /km	$\Omega$ /km
mm <sup>2</sup>	$\Omega$ /km				kV/mm	$\Omega$ /km	$\Omega$ /km	$\mu$ F/km	k $\Omega$ /km	A/km	mH/km	$\Omega$ /km	$\Omega$ /km
1x50RMC/16					3.85/1.40	2.20	0.093	0.13	25.2	0.71	0.47	0.148	0.835
											0.74	0.233	0.854
											0.66	0.206	0.847
1x70RMC/25					3.67/1.44	1.45	0.087	0.14	23.2	0.77	0.45	0.142	0.586
											0.72	0.225	0.611
											0.64	0.200	0.602
1x95RMC/35					3.48/1.50	1.04	0.080	0.15	20.9	0.86	0.43	0.134	0.432
											0.68	0.215	0.464
											0.61	0.192	0.453
1x120RMC/50					3.38/1.54	0.77	0.076	0.16	19.6	0.92	0.41	0.130	0.350
											0.67	0.210	0.386
											0.60	0.188	0.375
1x150RMC/50					3.26/1.58	0.71	0.071	0.18	18.1	1.00	0.40	0.124	0.292
											0.64	0.202	0.333
											0.58	0.183	0.321
1x185RMC/50					3.17/1.62	0.65	0.067	0.19	16.8	1.07	0.38	0.120	0.243
											0.63	0.197	0.288
											0.57	0.178	0.276
1x240RMC/50					3.08/1.66	0.60	0.063	0.21	15.4	1.17	0.37	0.115	0.198
											0.60	0.190	0.249
											0.55	0.174	0.237
1x300RMC/50					3.00/1.69	0.57	0.059	0.22	14.2	1.26	0.35	0.111	0.171
											0.59	0.184	0.225
											0.54	0.170	0.213
1x400RMC/50					2.91/1.73	0.54	0.055	0.25	12.9	1.40	0.34	0.107	0.147
											0.56	0.177	0.204
											0.52	0.165	0.194
1x500RMC/50					2.82/1.76	0.52	0.053	0.27	11.7	1.53	0.33	0.104	0.131
											0.55	0.172	0.190
											0.52	0.162	0.181

Nominal cross sectional area	Conductor resistance		Metallic screen resistance		Electrical field stress at conductor/insulation	Zero resistance $R_0$	Zero reactance $X_0$	Capacitance $C$	Capacitive reactance $X_c$	Charging current $I_c$	Inductance $L$	Inductive reactance $X_l$	Impedance
	DC 20°C	AC 90°C	DC 20°C	AC 80°C									
Conductor/ Metallic screen	DC 20°C	AC 90°C	DC 20°C	AC 80°C							$10^{-6}$	$10^{-6}$	$10^{-6}$
mm <sup>2</sup>	Ω/km				kV/mm	Ω/km	Ω/km	μF/km	kΩ/km	A/km	mH/km	Ω/km	Ω/km
1x630RMC/50	0.0469	0.0630	0.36	0.44	2.75/1.80	0.51	0.050	0.30	10.5	1.71	0.32	0.101	0.119
											0.53	0.166	0.177
											0.51	0.159	0.171
1x800RMC/50	0.0367	0.0507	0.36	0.44	2.69/1.84	0.49	0.047	0.33	9.5	1.89	0.31	0.098	0.110
											0.51	0.160	0.168
											0.50	0.156	0.164
1x1000RMC/50	0.0291	0.0420	0.36	0.44	2.63/1.87	0.48	0.044	0.37	8.5	2.12	0.30	0.094	0.103
											0.49	0.154	0.160
											0.49	0.152	0.158

## Current – carrying capacity

Nominal cross sectional area	Max short circuit capacity	GROUND				AIR						
				FLAT		TREFOIL		FLAT		TREFOIL		
		Conductor	Metallic screen	BE	SPB, CB	BE	SPB, CB	BE	SPB, CB	BE	SPB, CB	
mm <sup>2</sup>	kA/sec	A										
1x50RMC/16	4.7	3.7	219	220	208	209	229	230	200	200		
1x70RMC/25	6.6	5.3	267	270	255	256	282	284	247	247		
1x95RMC/35	9.0	7.1	319	325	307	308	341	347	300	301		
1x120RMC/50	11.3	9.8	357	371	348	350	387	399	343	345		
1x150RMC/50	14.2	9.8	402	418	392	395	438	455	390	393		
1x185RMC/50	17.5	9.8	452	476	445	450	499	523	447	451		
1x240RMC/50	22.7	9.8	517	555	517	524	580	618	524	531		
1x300RMC/50	28.4	9.8	577	630	584	594	657	710	600	609		
1x400RMC/50	37.8	9.8	650	728	670	684	756	833	699	712		
1x500RMC/50	47.3	9.8	726	834	763	784	858	969	808	828		
1x630RMC/50	59.5	9.8	811	961	870	900	978	1134	936	965		
1x800RMC/50	75.6	9.8	895	1095	980	1022	1097	1314	1071	1112		
1x1000RMC/50	94.5	9.8	980	1241	1091	1147	1222	1518	1216	1272		

## Operating Conditions

For laying in ground		For installation in air	
Depth of lay:	0,7 m.	Ambient temperature:	30°C
Ground temperature:	20°C	Protection from direct solar radiation	
Soil thermal resistivity:	1/ 2,5 K · m/W		

# MEDIUM VOLTAGE XLPE POWER CABLES

## 18/30 (36) kV

COPPER CONDUCTOR - Round, stranded and compacted conductor - Class 2  
N2XSY acc. to DIN VDE 0276-620 and HD 620S2:2010 part 10 section C  
2XSY acc. to IEC 60502-2:2005 and BS 6622:2007  
YHKXS acc. to ZN-TF-501:2002

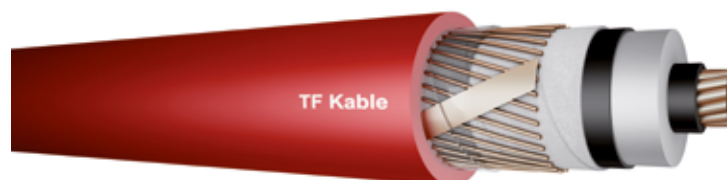

Conductor – nominal cross sectional area	Conductor diameter	Insulation		Metallic screen		Cable diameter D <sub>e</sub>	Cable weight	Maximum cable pulling force	Recommended min. bending radius for laying
		Thickness	Diameter over insulation	Cross sectional area	Diameter over metallic screen				
mm <sup>2</sup>	mm			mm <sup>2</sup>	mm	mm	kg/km	kN	m
1x35RMC	7.0 <sup>+0.15</sup>	8.0	24.2	16	28.1	32.9	1210	1.75	0.49
1x50RMC	8.25 <sup>+0.20</sup>	8.0	25.5	16	29.4	34.1	1370	2.5	0.51
1x70RMC	9.6 <sup>+0.20</sup>	8.0	26.8	25	30.7	35.5	1690	3.5	0.53
1x95RMC	11.5 <sup>+0.20</sup>	8.0	28.7	35	32.6	37.4	2080	4.75	0.56
1x120RMC	12.9 <sup>+0.25</sup>	8.0	30.1	50	34.0	38.8	2490	6	0.58
1x150RMC	14.5 <sup>+0.30</sup>	8.0	31.7	50	35.6	40.4	2800	7.5	0.61
1x185RMC	16.0 <sup>+0.30</sup>	8.0	33.2	50	37.1	41.9	3180	9.25	0.63
1x240RMC	18.5 <sup>+0.30</sup>	8.0	35.7	50	39.6	44.4	3760	12	0.67
1x300RMC	20.5 <sup>+0.30</sup>	8.0	37.7	50	41.6	46.4	4370	15	0.70
1x400RMC	23.5 <sup>+0.30</sup>	8.0	40.7	50	44.6	49.6	5290	20	0.74
1x500RMC	26.5 <sup>+0.40</sup>	8.0	44.2	50	48.3	53.5	6460	25	0.80
1x630RMC	30.3 <sup>+0.40</sup>	8.0	48.3	50	52.4	57.7	7880	31.5	0.87
1x800RMC	34.6 <sup>+0.50</sup>	8.0	53.0	50	57.1	62.8	9660	40	0.94
1x1000RMC	38.2 <sup>+0.40</sup>	8.0	56.6	50	60.7	66.6	11620	50	1.00

# Electrical data

RM (RMC) - Round Multiwire Conductor IC (C - compacted), Class 2

SPB - Single Point Bonded

CB - Cross Bonded

BE - Both Ends

$D_c$  - Cable diameter

2 - Cables in trefoil formation, the distance between cables  $D_e$

3 - Cables in flat formation (in the ground) – the distance between cables  $D_e + 70$  mm

4 - Cables in flat formation (in the air) – the distance between cables  $2 \times D_e$

Nominal cross sectional area	Conductor resistance		Metallic screen resistance		Electrical field stress at conductor/insulation	Zero resistance $R_0$	Zero reactance $X_0$	Capacitance $C$	Capacitive reactance $X_c$	Charging current $I_c$	Inductance $L$	Inductive reactance $X_l$	Impedance
	DC 20°C	AC 90°C	DC 20°C	AC 80°C							$0^0 0^2$	$0^0 0^2$	$0^0 0^2$
Conductor/Metallic screen	DC 20°C	AC 90°C	DC 20°C	AC 80°C							$0^0 0^3$	$0^0 0^3$	$0^0 0^3$
mm <sup>2</sup>	Ω/km				kV/mm	Ω/km	Ω/km	μF/km	kΩ/km	A/km	mH/km	Ω/km	Ω/km
1x35RMC/16					4.07/1.34	2.05	0.101	0.12	27.6	0.65	0.50	0.156	0.686
											0.77	0.243	0.711
											0.68	0.215	0.702
1x50RMC/16					3.85/1.40	1.88	0.093	0.13	25.2	0.71	0.47	0.148	0.516
											0.74	0.233	0.546
											0.66	0.206	0.535
1x70RMC/25					3.66/1.45	1.23	0.087	0.14	23.1	0.78	0.45	0.141	0.370
											0.71	0.224	0.409
											0.64	0.200	0.396
1x95RMC/35					3.47/1.51	0.88	0.079	0.15	20.7	0.87	0.42	0.133	0.280
											0.68	0.214	0.327
											0.61	0.191	0.312
1x120RMC/50					3.35/1.55	0.64	0.075	0.17	19.2	0.94	0.41	0.128	0.234
											0.66	0.208	0.285
											0.59	0.187	0.270
1x150RMC/50					3.25/1.59	0.60	0.070	0.18	17.8	1.01	0.39	0.124	0.201
											0.64	0.201	0.256
											0.58	0.182	0.241
1x185RMC/50					3.16/1.62	0.57	0.067	0.19	16.7	1.08	0.38	0.120	0.175
											0.62	0.196	0.234
											0.57	0.178	0.219
1x240RMC/50					3.05/1.67	0.54	0.062	0.21	15.1	1.19	0.36	0.114	0.150
											0.60	0.188	0.212
											0.55	0.172	0.198
1x300RMC/50					2.98/1.70	0.52	0.059	0.23	14.0	1.29	0.35	0.111	0.136
											0.58	0.183	0.199
											0.54	0.169	0.186
1x400RMC/50					2.90/1.74	0.50	0.054	0.25	12.6	1.42	0.34	0.106	0.123
											0.56	0.176	0.187
											0.52	0.164	0.176
1x500RMC/50					2.80/1.77	0.49	0.052	0.28	11.5	1.57	0.33	0.103	0.115
											0.54	0.170	0.178
											0.51	0.161	0.169

Nominal cross sectional area	Conductor resistance		Metallic screen resistance		Electrical field stress at conductor/insulation	Zero resistance $R_0$	Zero reactance $X_0$	Capacitance $C$	Capacitive reactance $X_c$	Charging current $I_c$	Inductance $L$	Inductive reactance $X_l$	Impedance
	DC 20°C	AC 90°C	DC 20°C	AC 80°C									
Conductor/ Metallic screen	DC 20°C	AC 90°C	DC 20°C	AC 80°C									
mm <sup>2</sup>	Ω/km				kV/mm	Ω/km	Ω/km	μF/km	kΩ/km	A/km	mH/km	Ω/km	Ω/km
1x630RMC/50											0.32	0.100	0.108
											0.52	0.164	0.169
											0.50	0.158	0.163
1x800RMC/50											0.31	0.097	0.102
											0.50	0.158	0.162
											0.49	0.155	0.158
1x1000RMC/50											0.30	0.094	0.098
											0.49	0.154	0.157
											0.48	0.152	0.155

## Current – carrying capacity

Nominal cross sectional area	Max short circuit capacity	GROUND				AIR						
				FLAT		TREFOIL		FLAT		TREFOIL		
		Conductor	Metallic screen	BE	SPB, CB	BE	SPB, CB	BE	SPB, CB	BE	SPB, CB	
mm <sup>2</sup>	kA/sec	A										
1x35RMC/16	5.0	3.7	237	239	226	226	246	247	215	216		
1x50RMC/16	7.2	3.7	282	284	269	269	294	296	258	258		
1x70RMC/25	10.0	5.3	342	348	329	330	361	367	318	319		
1x95RMC/35	13.6	7.1	407	420	396	398	436	449	387	389		
1x120RMC/50	17.2	9.8	453	480	448	453	492	518	443	447		
1x150RMC/50	21.5	9.8	503	541	504	511	555	590	503	509		
1x185RMC/50	26.5	9.8	559	614	569	579	626	676	572	582		
1x240RMC/50	34.3	9.8	636	717	661	676	726	802	674	688		
1x300RMC/50	42.9	9.8	702	814	744	765	814	919	767	786		
1x400RMC/50	57.2	9.8	779	934	845	875	923	1072	885	913		
1x500RMC/50	71.5	9.8	859	1066	953	995	1035	1242	1014	1053		
1x630RMC/50	90.1	9.8	946	1220	1072	1129	1163	1446	1160	1215		
1x800RMC/50	114.4	9.8	1029	1379	1187	1263	1283	1663	1309	1384		
1x1000RMC/50	143.0	9.8	1098	1529	1289	1386	1389	1871	1442	1538		

## Operating Conditions

For laying in ground		For installation in air	
Depth of lay:	0,7 m.	Ambient temperature:	30°C
Ground temperature:	20°C	Protection from direct solar radiation	
Soil thermal resistivity:	1/ 2,5 K · m/W		

# MEDIUM VOLTAGE XLPE POWER CABLES – Longitudinally Sealed

## 18/30 (36) kV

ALUMINIUM CONDUCTOR - Round, stranded and compacted conductor - Class 2  
NA2XS(F)2Y acc. to DIN VDE 0276-620 and HD 620S2:2010 part 10 section C  
A2XS(F)2Y acc. to IEC 60502-2:2005 and BS 6622:2007  
XUHAKXS acc. ZN-TF-501:2002

52



Conductor – nominal cross sectional area	Conductor diameter	Insulation		Metallic screen		Cable diameter $D_e$	Cable weight	Maximum cable pulling force	Recommended min. bending radius for laying
		Thickness	Diameter over insulation	Cross sectional area	Diameter over metallic screen				
mm <sup>2</sup>	mm			mm <sup>2</sup>	mm	mm	kg/km	kN	m
1x50RMC	8.25 <sup>+0.10</sup>	8.0	25.5	16	29.6	35.1	1000	1.5	0.53
1x70RMC	9.5 <sup>+0.20</sup>	8.0	26.7	25	30.8	36.4	1190	2.1	0.55
1x95RMC	11.3 <sup>+0.20</sup>	8.0	28.5	35	32.6	38.2	1410	2.85	0.57
1x120RMC	12.5 <sup>+0.20</sup>	8.0	29.7	50	33.8	39.4	1660	3.6	0.59
1x150RMC	14.2 <sup>+0.20</sup>	8.0	31.4	50	35.5	41.1	1800	4.5	0.62
1x185RMC	15.8 <sup>+0.20</sup>	8.0	33.0	50	37.1	42.7	1960	5.55	0.64
1x240RMC	17.9 <sup>+0.10</sup>	8.0	35.1	50	39.2	44.8	2180	7.2	0.67
1x300RMC	20.0 <sup>+0.30</sup>	8.0	37.2	50	41.3	46.9	2410	9	0.70
1x400RMC	22.9 <sup>+0.30</sup>	8.0	40.1	50	44.2	49.8	2740	12	0.75
1x500RMC	25.7 <sup>+0.40</sup>	8.0	43.4	50	47.7	53.7	3210	15	0.81
1x630RMC	29.3 <sup>+0.50</sup>	8.0	47.3	50	51.6	57.7	3740	18.9	0.87
1x800RMC	33.0 <sup>+0.50</sup>	8.0	51.4	50	55.7	62.0	4380	24	0.93
1x1000RMC	38.0 <sup>+0.50</sup>	8.0	56.4	50	60.7	67.4	5160	30	1.01

# Electrical data

RM (RMC) - Round Multiwire Conductor IC (C - compacted), Class 2  
 SPB - Single Point Bonded  
 CB - Cross Bonded  
 BE - Both Ends  
 D<sub>e</sub> - Cable diameter

2 - Cables in trefoil formation, the distance between cables D<sub>e</sub>  
 3 - Cables in flat formation (in the ground) – the distance between cables D<sub>e</sub> + 70 mm  
 4 - Cables in flat formation (in the air) – the distance between cables 2 x D<sub>e</sub>

Nominal cross sectional area	Conductor resistance		Metallic screen resistance		Electrical field stress at conductor/insulation	Zero resistance R <sub>0</sub>	Zero reactance X <sub>0</sub>	Capacitance C	Capacitive reactance X <sub>c</sub>	Charging current I <sub>c</sub>	Inductance L	Inductive reactance XI	Impedance
	DC 20°C	AC 90°C	DC 20°C	AC 80°C							o <sup>0</sup> o <sup>2</sup>	o <sup>0</sup> o <sup>2</sup>	o <sup>0</sup> o <sup>2</sup>
Conductor/Metallic screen	DC 20°C	AC 90°C	DC 20°C	AC 80°C							ooo <sup>3</sup>	ooo <sup>3</sup>	ooo <sup>3</sup>
mm <sup>2</sup>	Ω/km				kV/mm	Ω/km	Ω/km	μF/km	kΩ/km	A/km	mH/km	Ω/km	Ω/km
1x50RMC/16	0.641	0.822	1.12	1.38	3.85/1.40	2.20	0.094	0.13	25.2	0.71	0.48	0.150	0.836
											0.74	0.234	0.855
											0.66	0.208	0.848
1x70RMC/25	0.443	0.568	0.72	0.89	3.67/1.44	1.45	0.087	0.14	23.2	0.77	0.46	0.144	0.586
											0.72	0.226	0.611
											0.64	0.202	0.603
1x95RMC/35	0.320	0.411	0.51	0.63	3.48/1.50	1.04	0.080	0.15	20.9	0.86	0.43	0.136	0.432
											0.69	0.216	0.464
											0.62	0.194	0.454
1x120RMC/50	0.253	0.325	0.36	0.44	3.38/1.54	0.77	0.076	0.16	19.6	0.92	0.42	0.131	0.350
											0.67	0.210	0.387
											0.60	0.189	0.376
1x150RMC/50	0.206	0.265	0.36	0.44	3.26/1.58	0.71	0.071	0.18	18.1	1.00	0.40	0.126	0.293
											0.65	0.203	0.334
											0.59	0.184	0.322
1x185RMC/50	0.164	0.211	0.36	0.44	3.17/1.62	0.65	0.067	0.19	16.8	1.07	0.39	0.122	0.243
											0.63	0.197	0.289
											0.57	0.180	0.277
1x240RMC/50	0.125	0.161	0.36	0.44	3.08/1.66	0.60	0.063	0.21	15.4	1.17	0.37	0.117	0.199
											0.61	0.191	0.250
											0.56	0.175	0.238
1x300RMC/50	0.100	0.129	0.36	0.44	3.00/1.69	0.57	0.060	0.22	14.2	1.26	0.36	0.113	0.172
											0.59	0.185	0.226
											0.54	0.171	0.214
1x400RMC/50	0.0778	0.101	0.36	0.44	2.91/1.73	0.54	0.055	0.25	12.9	1.40	0.34	0.108	0.148
											0.57	0.178	0.205
											0.53	0.166	0.195
1x500RMC/50	0.0605	0.0797	0.36	0.44	2.82/1.76	0.52	0.053	0.27	11.7	1.53	0.34	0.106	0.132
											0.55	0.173	0.190
											0.52	0.164	0.182

Nominal cross sectional area	Conductor resistance		Metallic screen resistance		Electrical field stress at conductor/insulation	Zero resistance $R_0$	Zero reactance $X_0$	Capacitance $C$	Capacitive reactance $X_c$	Charging current $I_c$	Inductance $L$	Inductive reactance $X_l$	Impedance
	DC 20°C	AC 90°C	DC 20°C	AC 80°C									
Conductor/ Metallic screen	DC 20°C	AC 90°C	DC 20°C	AC 80°C	kV/mm	$\Omega/km$	$\Omega/km$	$\mu F/km$	k $\Omega/km$	A/km	mH/km	$\Omega/km$	$\Omega/km$
mm <sup>2</sup>	$\Omega/km$												
1x630RMC/50	0.0469	0.0629	0.36	0.44	2.75/1.80	0.51	0.050	0.30	10.5	1.71	0.32	0.102	0.120
											0.53	0.166	0.178
											0.51	0.160	0.172
1x800RMC/50	0.0367	0.0506	0.36	0.44	2.69/1.84	0.49	0.047	0.33	9.5	1.89	0.31	0.099	0.111
											0.51	0.161	0.169
											0.50	0.157	0.165
1x1000RMC/50	0.0291	0.0419	0.36	0.44	2.63/1.87	0.48	0.044	0.37	8.5	2.12	0.30	0.095	0.104
											0.49	0.155	0.160
											0.49	0.153	0.159

## Current – carrying capacity

Nominal cross sectional area	Max short circuit capacity	GROUND				AIR					
		Conductor	Metallic screen	FLAT		TREFOIL		FLAT		TREFOIL	
				BE	SPB, CB	BE	SPB, CB	BE	SPB, CB	BE	SPB, CB
mm <sup>2</sup>	kA/sec	A									
1x50RMC/16	4.7	3.7	221	222	210	211	232	233	202	202	
1x70RMC/25	6.6	5.3	270	272	257	258	285	288	249	250	
1x95RMC/35	9.0	7.1	322	328	309	311	346	352	303	304	
1x120RMC/50	11.3	9.8	362	374	351	354	392	405	347	349	
1x150RMC/50	14.2	9.8	406	422	396	399	445	462	394	397	
1x185RMC/50	17.5	9.8	457	481	449	454	507	531	452	456	
1x240RMC/50	22.7	9.8	523	560	521	528	590	627	530	537	
1x300RMC/50	28.4	9.8	583	636	589	599	668	721	607	616	
1x400RMC/50	37.8	9.8	657	734	676	690	769	846	707	720	
1x500RMC/50	47.3	9.8	734	843	769	791	874	984	818	838	
1x630RMC/50	59.5	9.8	820	970	877	907	997	1153	948	977	
1x800RMC/50	75.6	9.8	905	1106	989	1031	1120	1336	1085	1126	
1x1000RMC/50	94.5	9.8	992	1253	1101	1158	1250	1546	1234	1290	

## Operating Conditions

For laying in ground		For installation in air	
Depth of lay:	0,7 m.	Ambient temperature:	30°C
Ground temperature:	20°C	Protection from direct solar radiation	
Soil thermal resistivity:	1/ 2,5 K · m/W		

# MEDIUM VOLTAGE XLPE POWER CABLES – Longitudinally Sealed

## 18/30 (36) kV

COPPER CONDUCTOR - Round, stranded and compacted conductor - Class 2  
N2XS(F)2Y acc. to DIN VDE 0276-620 and HD 62052:2010 part 10 section C  
2XS(F)2Y acc. to IEC 60502-2:2005 and BS 6622:2007  
XUHKXS acc. ZN-TF-501:2002

55



Conductor – nominal cross sectional area	Conductor diameter	Insulation		Metallic screen		Cable diameter D <sub>e</sub>	Cable weight	Maximum cable pulling force	Recommended min. bending radius for laying
		Thickness	Diameter over insulation	Cross sectional area	Diameter over metallic screen				
mm <sup>2</sup>	mm			mm <sup>2</sup>	mm	mm	kg/km	kN	m
1x35RMC	7.0 <sup>+0.15</sup>	8.0	24.2	16	28.3	33.9	1140	1.75	0.51
1x50RMC	8.25 <sup>+0.20</sup>	8.0	25.5	16	29.6	35.1	1290	2.5	0.53
1x70RMC	9.6 <sup>+0.20</sup>	8.0	26.8	25	30.9	36.5	1600	3.5	0.55
1x95RMC	11.5 <sup>+0.20</sup>	8.0	28.7	35	32.8	38.4	1990	4.75	0.58
1x120RMC	12.9 <sup>+0.25</sup>	8.0	30.1	50	34.2	39.8	2400	6	0.60
1x150RMC	14.5 <sup>+0.30</sup>	8.0	31.7	50	35.8	41.4	2710	7.5	0.62
1x185RMC	16.0 <sup>+0.30</sup>	8.0	33.2	50	37.3	42.9	3080	9.25	0.64
1x240RMC	18.5 <sup>+0.30</sup>	8.0	35.7	50	39.8	45.4	3660	12	0.68
1x300RMC	20.5 <sup>+0.30</sup>	8.0	37.7	50	41.8	47.4	4270	15	0.71
1x400RMC	23.5 <sup>+0.30</sup>	8.0	40.7	50	44.8	50.6	5170	20	0.76
1x500RMC	26.5 <sup>+0.40</sup>	8.0	44.2	50	48.5	54.5	6330	25	0.82
1x630RMC	30.3 <sup>+0.40</sup>	8.0	48.3	50	52.6	58.7	7720	31.5	0.88
1x800RMC	34.6 <sup>+0.50</sup>	8.0	53.0	50	57.3	63.8	9470	40	0.96
1x1000RMC	38.2 <sup>+0.40</sup>	8.0	56.6	50	60.9	67.6	11410	50	1.01

# Electrical data

RM (RMC) - Round Multiwire Conductor IC (C - compacted), Class 2  
 SPB - Single Point Bonded  
 CB - Cross Bonded  
 BE - Both Ends  
 $D_e$  - Cable diameter

2 - Cables in trefoil formation, the distance between cables  $D_e$   
 3 - Cables in flat formation (in the ground) – the distance between cables  $D_e + 70$  mm  
 4 - Cables in flat formation (in the air) – the distance between cables  $2 \times D_e$

Nominal cross sectional area	Conductor resistance		Metallic screen resistance		Electrical field stress at conductor/insulation	Zero resistance $R_0$	Zero reactance $X_0$	Capacitance $C$	Capacitive reactance $X_c$	Charging current $I_c$	Inductance L	Inductive reactance XI	Impedance
	DC 20°C	AC 90°C	DC 20°C	AC 80°C							$0^0 0^2$	$0^0 0^2$	$0^0 0^2$
Conductor/Metallic screen	DC 20°C	AC 90°C	DC 20°C	AC 80°C							$0^0 0^3$	$0^0 0^3$	$0^0 0^3$
mm <sup>2</sup>	$\Omega/km$				kV/mm	$\Omega/km$	$\Omega/km$	$\mu F/km$	k $\Omega/km$	A/km	mH/km	$\Omega/km$	$\Omega/km$
1x35RMC/16	0.524	0.668	1.12	1.38	4.07/1.34	2.05	0.101	0.12	27.6	0.65	0.50	0.158	0.687
											0.77	0.243	0.711
											0.69	0.216	0.702
1x50RMC/16	0.387	0.494	1.12	1.38	3.85/1.40	1.88	0.094	0.13	25.2	0.71	0.48	0.150	0.516
											0.74	0.234	0.546
											0.66	0.208	0.536
1x70RMC/25	0.268	0.342	0.72	0.89	3.66/1.45	1.23	0.087	0.14	23.1	0.78	0.46	0.143	0.371
											0.72	0.225	0.409
											0.64	0.201	0.397
1x95RMC/35	0.193	0.247	0.51	0.63	3.47/1.51	0.88	0.079	0.15	20.7	0.87	0.43	0.135	0.281
											0.68	0.215	0.327
											0.61	0.193	0.313
1x120RMC/50	0.153	0.196	0.36	0.44	3.35/1.55	0.64	0.075	0.17	19.2	0.94	0.41	0.130	0.235
											0.66	0.208	0.286
											0.60	0.188	0.271
1x150RMC/50	0.124	0.159	0.36	0.44	3.25/1.59	0.60	0.071	0.18	17.8	1.01	0.40	0.125	0.202
											0.64	0.202	0.257
											0.58	0.183	0.243
1x185RMC/50	0.0991	0.127	0.36	0.44	3.16/1.62	0.57	0.067	0.19	16.7	1.08	0.39	0.121	0.176
											0.63	0.197	0.234
											0.57	0.179	0.220
1x240RMC/50	0.0754	0.0976	0.36	0.44	3.05/1.67	0.54	0.062	0.21	15.1	1.19	0.37	0.116	0.151
											0.60	0.189	0.213
											0.55	0.174	0.199
1x300RMC/50	0.0601	0.0785	0.36	0.44	2.98/1.70	0.52	0.059	0.23	14.0	1.29	0.36	0.112	0.137
											0.58	0.183	0.200
											0.54	0.170	0.187
1x400RMC/50	0.0470	0.0625	0.36	0.44	2.90/1.74	0.50	0.055	0.25	12.6	1.42	0.34	0.107	0.124
											0.56	0.177	0.187
											0.53	0.166	0.177
1x500RMC/50	0.0366	0.0500	0.36	0.44	2.80/1.77	0.49	0.052	0.28	11.5	1.57	0.33	0.105	0.116
											0.54	0.171	0.178
											0.52	0.163	0.170

Nominal cross sectional area	Conductor resistance		Metallic screen resistance		Electrical field stress at conductor/insulation	Zero resistance $R_0$	Zero reactance $X_0$	Capacitance $C$	Capacitive reactance $X_c$	Charging current $I_c$	Inductance $L$	Inductive reactance $X_L$	Impedance
	DC 20°C	AC 90°C	DC 20°C	AC 80°C									
Conductor/ Metallic screen	DC 20°C	AC 90°C	DC 20°C	AC 80°C	kV/mm	Ω/km	Ω/km	μF/km	kΩ/km	A/km	mH/km	Ω/km	Ω/km
mm <sup>2</sup>	Ω/km				kV/mm	Ω/km	Ω/km	μF/km	kΩ/km	A/km	mH/km	Ω/km	Ω/km
1x630RMC/50	0.0283	0.0404	0.36	0.44	2.73/1.81	0.48	0.049	0.31	10.3	1.75	0.32	0.101	0.109
											0.52	0.165	0.170
											0.51	0.159	0.164
1x800RMC/50	0.0221	0.0335	0.36	0.44	2.67/1.85	0.48	0.046	0.35	9.2	1.97	0.31	0.098	0.103
											0.51	0.159	0.162
											0.50	0.156	0.159
1x1000RMC/50	0.0176	0.0287	0.36	0.44	2.63/1.87	0.47	0.044	0.38	8.5	2.13	0.30	0.095	0.099
											0.49	0.154	0.157
											0.49	0.153	0.156

## Current – carrying capacity

Nominal cross sectional area	Max short circuit capacity	GROUND				AIR						
		FLAT		TREFOIL		FLAT		TREFOIL				
		Conductor	Metallic screen	BE	SPB, CB	BE	SPB, CB	BE	SPB, CB	BE	SPB, CB	
mm <sup>2</sup>	kA/sec	A										
1x35RMC/16	5.0	3.7	240	241	228	228	249	250	218	218		
1x50RMC/16	7.2	3.7	284	287	271	272	298	300	261	261		
1x70RMC/25	10.0	5.3	345	352	332	333	367	372	321	322		
1x95RMC/35	13.6	7.1	411	425	399	402	443	456	391	394		
1x120RMC/50	17.2	9.8	458	485	452	457	500	525	448	452		
1x150RMC/50	21.5	9.8	509	547	509	516	564	599	509	515		
1x185RMC/50	26.5	9.8	566	620	575	584	636	686	579	588		
1x240RMC/50	34.3	9.8	643	724	667	682	738	813	682	695		
1x300RMC/50	42.9	9.8	710	821	750	771	829	933	776	795		
1x400RMC/50	57.2	9.8	788	943	853	883	940	1089	895	924		
1x500RMC/50	71.5	9.8	869	1077	962	1004	1056	1262	1026	1066		
1x630RMC/50	90.1	9.8	957	1232	1082	1139	1187	1470	1175	1231		
1x800RMC/50	114.4	9.8	1041	1393	1198	1274	1313	1693	1327	1403		
1x1000RMC/50	143.0	9.8	1111	1545	1301	1398	1423	1905	1463	1559		

## Operating Conditions

For laying in ground		For installation in air	
Depth of lay:	0,7 m.	Ambient temperature:	30°C
Ground temperature:	20°C	Protection from direct solar radiation	
Soil thermal resistivity:	1/ 2,5 K · m/W		

# MEDIUM VOLTAGE XLPE POWER CABLES – Longitudinally and Radially Sealed

## 18/30 (36) kV

58

ALUMINIUM CONDUCTOR - Round, stranded and compacted conductor - Class 2  
NA2XS(FL)2Y acc. to DIN VDE 0276-620 and HD 620S2:2010 part 10 section C  
A2XS(FL)2Y acc. to IEC 60502-2:2005 and BS 6622:2007  
XRUHAKXS acc. ZN-TF-501:2002

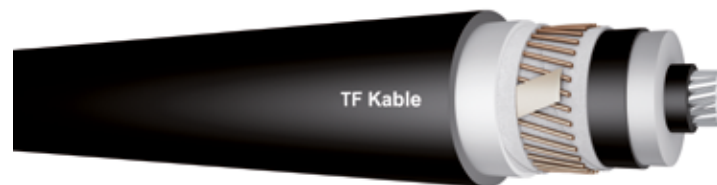

Conductor – nominal cross sectional area	Conductor diameter	Insulation		Metallic screen		Cable diameter D <sub>e</sub>	Cable weight	Maximum cable pulling force	Recommended min. bending radius for laying
		Thickness	Diameter over insulation	Cross sectional area	Diameter over metallic screen				
mm <sup>2</sup>	mm			mm <sup>2</sup>	mm	mm	kg/km	kN	m
1x50RMC	8.25 <sup>+0.10</sup>	8.0	25.5	16	29.5	35.6	1080	1.5	0.78
1x70RMC	9.5 <sup>+0.20</sup>	8.0	26.7	25	30.8	36.8	1270	2.1	0.81
1x95RMC	11.3 <sup>+0.20</sup>	8.0	28.5	35	32.6	38.6	1500	2.85	0.85
1x120RMC	12.5 <sup>+0.20</sup>	8.0	29.7	50	33.8	39.8	1750	3.6	0.88
1x150RMC	14.2 <sup>+0.20</sup>	8.0	31.4	50	35.5	41.5	1880	4.5	0.92
1x185RMC	15.8 <sup>+0.20</sup>	8.0	33.0	50	37.1	43.1	2040	5.55	0.96
1x240RMC	17.9 <sup>+0.10</sup>	8.0	35.1	50	39.2	45.2	2270	7.2	1.02
1x300RMC	20.0 <sup>+0.30</sup>	8.0	37.2	50	41.3	47.3	2500	9	1.07
1x400RMC	22.9 <sup>+0.30</sup>	8.0	40.1	50	44.2	50.4	2850	12	1.15
1x500RMC	25.7 <sup>+0.40</sup>	8.0	43.4	50	47.7	54.1	3320	15	1.24
1x630RMC	29.3 <sup>+0.50</sup>	8.0	47.3	50	51.5	58.4	3880	18.9	1.34
1x800RMC	33.0 <sup>+0.50</sup>	8.0	51.4	50	55.6	62.7	4520	24	1.44
1x1000RMC	38.0 <sup>+0.50</sup>	8.0	56.4	50	60.6	68.1	5320	30	1.57

# Electrical data

RM (RMC) - Round Multiwire Conductor IC (C - compacted), Class 2

SPB - Single Point Bonded

CB - Cross Bonded

BE - Both Ends

D<sub>e</sub> - Cable diameter

2 - Cables in trefoil formation, the distance between cables D<sub>e</sub>

3 - Cables in flat formation (in the ground) – the distance between cables D<sub>e</sub> + 70 mm

4 - Cables in flat formation (in the air) – the distance between cables 2 x D<sub>e</sub>

Nominal cross sectional area	Conductor resistance		Metallic screen resistance		Electrical field stress at conductor/insulation	Zero resistance R <sub>0</sub>	Zero reactance X <sub>0</sub>	Capacitance C	Capacitive reactance X <sub>c</sub>	Charging current I <sub>c</sub>	Inductance L	Inductive reactance XI	Impedance
	DC 20°C	AC 90°C	DC 20°C	AC 80°C							o <sup>0</sup> o <sup>2</sup>	o <sup>0</sup> o <sup>2</sup>	o <sup>0</sup> o <sup>2</sup>
Conductor/ Metallic screen	DC 20°C	AC 90°C	DC 20°C	AC 80°C							ooo <sup>3</sup>	ooo <sup>3</sup>	ooo <sup>3</sup>
mm <sup>2</sup>	Ω/km				kV/mm	Ω/km	Ω/km	μF/km	kΩ/km	A/km	mH/km	Ω/km	Ω/km
1x50RMC/16											0.48	0.151	0.836
											0.74	0.234	0.855
											0.67	0.209	0.848
1x70RMC/25											0.46	0.144	0.586
											0.72	0.226	0.611
											0.64	0.202	0.603
1x95RMC/35											0.43	0.136	0.433
											0.69	0.216	0.464
											0.62	0.195	0.454
1x120RMC/50											0.42	0.132	0.351
											0.67	0.210	0.387
											0.61	0.190	0.376
1x150RMC/50											0.40	0.127	0.293
											0.65	0.203	0.334
											0.59	0.185	0.323
1x185RMC/50											0.39	0.122	0.244
											0.63	0.197	0.289
											0.57	0.180	0.278
1x240RMC/50											0.37	0.117	0.199
											0.61	0.191	0.250
											0.56	0.176	0.238
1x300RMC/50											0.36	0.113	0.172
											0.59	0.185	0.226
											0.55	0.171	0.215
1x400RMC/50											0.35	0.109	0.149
											0.57	0.178	0.205
											0.53	0.167	0.195
1x500RMC/50											0.34	0.106	0.133
											0.55	0.173	0.190
											0.52	0.164	0.182
1x500RMC/50											0.33	0.105	0.116
											0.54	0.171	0.178
											0.52	0.163	0.170

Nominal cross sectional area	Conductor resistance		Metallic screen resistance		Electrical field stress at conductor/insulation	Zero resistance $R_0$	Zero reactance $X_0$	Capacitance $C$	Capacitive reactance $X_c$	Charging current $I_c$	Inductance $L$	Inductive reactance $X_l$	Impedance
	DC 20°C	AC 90°C	DC 20°C	AC 80°C									
Conductor/ Metallic screen	DC 20°C	AC 90°C	DC 20°C	AC 80°C									
mm <sup>2</sup>	Ω/km				kV/mm	Ω/km	Ω/km	μF/km	kΩ/km	A/km	mH/km	Ω/km	Ω/km
1x630RMC/50	0.0283	0.0404	0.36	0.44	2.73/1.81	0.48	0.049	0.31	10.3	1.75	0.32	0.101	0.109
											0.52	0.165	0.170
											0.51	0.159	0.164
1x800RMC/50	0.0221	0.0335	0.36	0.44	2.67/1.85	0.48	0.046	0.35	9.2	1.97	0.31	0.098	0.103
											0.51	0.159	0.162
											0.50	0.156	0.159
1x1000RMC/50	0.0176	0.0287	0.36	0.44	2.63/1.87	0.47	0.044	0.38	8.5	2.13	0.30	0.095	0.099
											0.49	0.154	0.157
											0.49	0.153	0.156

## Current – carrying capacity

Nominal cross sectional area	Max short circuit capacity	GROUND				AIR						
		FLAT		TREFOIL		FLAT		TREFOIL				
		Conductor	Metallic screen	BE	SPB, CB	BE	SPB, CB	BE	SPB, CB	BE	SPB, CB	
mm <sup>2</sup>	kA/sec	A										
1x35RMC/16	5.0	3.7	240	241	228	228	249	250	218	218		
1x50RMC/16	7.2	3.7	284	287	271	272	298	300	261	261		
1x70RMC/25	10.0	5.3	345	352	332	333	367	372	321	322		
1x95RMC/35	13.6	7.1	411	425	399	402	443	456	391	394		
1x120RMC/50	17.2	9.8	458	485	452	457	500	525	448	452		
1x150RMC/50	21.5	9.8	509	547	509	516	564	599	509	515		
1x185RMC/50	26.5	9.8	566	620	575	584	636	686	579	588		
1x240RMC/50	34.3	9.8	643	724	667	682	738	813	682	695		
1x300RMC/50	42.9	9.8	710	821	750	771	829	933	776	795		
1x400RMC/50	57.2	9.8	788	943	853	883	940	1089	895	924		
1x500RMC/50	71.5	9.8	869	1077	962	1004	1056	1262	1026	1066		
1x630RMC/50	90.1	9.8	957	1232	1082	1139	1187	1470	1175	1231		
1x800RMC/50	114.4	9.8	1041	1393	1198	1274	1313	1693	1327	1403		
1x1000RMC/50	143.0	9.8	1111	1545	1301	1398	1423	1905	1463	1559		

## Operating Conditions

For laying in ground		For installation in air	
Depth of lay:	0,7 m.	Ambient temperature:	30°C
Ground temperature:	20°C	Protection from direct solar radiation	
Soil thermal resistivity:	1/ 2,5 K · m/W		

# MEDIUM VOLTAGE XLPE POWER CABLES – Longitudinally and Radially Sealed

## 18/30 (36) kV

ALUMINIUM CONDUCTOR - Round, stranded and compacted conductor - Class 2  
NA2XS(FL)2Y acc. to DIN VDE 0276-620 and HD 620S2:2010 part 10 section C  
A2XS(FL)2Y acc. to IEC 60502-2:2005 and BS 6622:2007  
XRUHAKXS acc. ZN-TF-501:2002

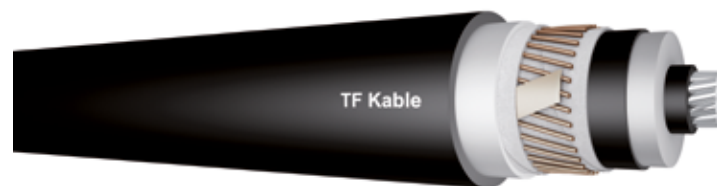

Conductor – nominal cross sectional area	Conductor diameter	Insulation		Metallic screen		Cable diameter D <sub>e</sub>	Cable weight	Maximum cable pulling force	Recommended min. bending radius for laying
		Thickness	Diameter over insulation	Cross sectional area	Diameter over metallic screen				
mm <sup>2</sup>	mm			mm <sup>2</sup>	mm	mm	kg/km	kN	m
1x50RMC	8.25 <sup>+0.10</sup>	8.0	25.5	16	29.5	35.6	1080	1.5	0.78
1x70RMC	9.5 <sup>+0.20</sup>	8.0	26.7	25	30.8	36.8	1270	2.1	0.81
1x95RMC	11.3 <sup>+0.20</sup>	8.0	28.5	35	32.6	38.6	1500	2.85	0.85
1x120RMC	12.5 <sup>+0.20</sup>	8.0	29.7	50	33.8	39.8	1750	3.6	0.88
1x150RMC	14.2 <sup>+0.20</sup>	8.0	31.4	50	35.5	41.5	1880	4.5	0.92
1x185RMC	15.8 <sup>+0.20</sup>	8.0	33.0	50	37.1	43.1	2040	5.55	0.96
1x240RMC	17.9 <sup>+0.10</sup>	8.0	35.1	50	39.2	45.2	2270	7.2	1.02
1x300RMC	20.0 <sup>+0.30</sup>	8.0	37.2	50	41.3	47.3	2500	9	1.07
1x400RMC	22.9 <sup>+0.30</sup>	8.0	40.1	50	44.2	50.4	2850	12	1.15
1x500RMC	25.7 <sup>+0.40</sup>	8.0	43.4	50	47.7	54.1	3320	15	1.24
1x630RMC	29.3 <sup>+0.50</sup>	8.0	47.3	50	51.5	58.4	3880	18.9	1.34
1x800RMC	33.0 <sup>+0.50</sup>	8.0	51.4	50	55.6	62.7	4520	24	1.44
1x1000RMC	38.0 <sup>+0.50</sup>	8.0	56.4	50	60.6	68.1	5320	30	1.57

# Electrical data

RM (RMC) - Round Multiwire Conductor IC (C - compacted), Class 2

SPB - Single Point Bonded

CB - Cross Bonded

BE - Both Ends

$D_e$  - Cable diameter

2 - Cables in trefoil formation, the distance between cables  $D_e$

3 - Cables in flat formation (in the ground) – the distance between cables  $D_e + 70$  mm

4 - Cables in flat formation (in the air) – the distance between cables  $2 \times D_e$

Nominal cross sectional area	Conductor resistance		Metallic screen resistance		Electrical field stress at conductor/insulation	Zero resistance $R_0$	Zero reactance $X_0$	Capacitance $C$	Capacitive reactance $X_c$	Charging current $I_c$	Inductance L	Inductive reactance XI	Impedance	
	DC 20°C	AC 90°C	DC 20°C	AC 80°C							$\frac{0^0}{0^0 0^2}$	$\frac{0^0}{0^0 0^2}$	$\frac{0^0}{0^0 0^2}$	
Conductor/Metallic screen	mm <sup>2</sup>	Ω/km	Ω/km	Ω/km	kV/mm	Ω/km	Ω/km	μF/km	kΩ/km	A/km	mH/km	Ω/km	Ω/km	
1x50RMC/16		0.641	0.822	1.12	1.38	3.85/1.40	1.55	0.095	0.13	25.2	0.71	0.48	0.151	0.836
												0.74	0.234	0.855
												0.67	0.209	0.848
1x70RMC/25		0.443	0.568	0.72	0.89	3.67/1.44	1.12	0.089	0.14	23.2	0.77	0.46	0.144	0.586
												0.72	0.226	0.611
												0.64	0.202	0.603
1x95RMC/35		0.320	0.411	0.51	0.63	3.48/1.50	0.85	0.082	0.15	20.9	0.86	0.43	0.136	0.433
												0.69	0.216	0.464
												0.62	0.195	0.454
1x120RMC/50		0.253	0.325	0.36	0.44	3.38/1.54	0.66	0.078	0.16	19.6	0.92	0.42	0.132	0.351
												0.67	0.210	0.387
												0.61	0.190	0.376
1x150RMC/50		0.206	0.265	0.36	0.44	3.26/1.58	0.60	0.073	0.18	18.1	1.00	0.40	0.127	0.293
												0.65	0.203	0.334
												0.59	0.185	0.323
1x185RMC/50		0.164	0.211	0.36	0.44	3.17/1.62	0.54	0.069	0.19	16.8	1.07	0.39	0.122	0.244
												0.63	0.197	0.289
												0.57	0.180	0.278
1x240RMC/50		0.125	0.161	0.36	0.44	3.08/1.66	0.49	0.064	0.21	15.4	1.17	0.37	0.117	0.199
												0.61	0.191	0.250
												0.56	0.176	0.238
1x300RMC/50		0.100	0.129	0.36	0.44	3.00/1.69	0.45	0.061	0.22	14.2	1.26	0.36	0.113	0.172
												0.59	0.185	0.226
												0.55	0.171	0.215
1x400RMC/50		0.0778	0.101	0.36	0.44	2.91/1.73	0.42	0.057	0.25	12.9	1.40	0.35	0.109	0.149
												0.57	0.178	0.205
												0.53	0.167	0.195
1x500RMC/50		0.0605	0.0797	0.36	0.44	2.82/1.76	0.39	0.054	0.27	11.7	1.53	0.34	0.106	0.133
												0.55	0.173	0.190
												0.52	0.164	0.182

Nominal cross sectional area	Conductor resistance		Metallic screen resistance		Electrical field stress at conductor/insulation	Zero resistance $R_0$	Zero reactance $X_0$	Capacitance $C$	Capacitive reactance $X_c$	Charging current $I_c$	Inductance $L$	Inductive reactance $X_L$	Impedance
	DC 20°C	AC 90°C	DC 20°C	AC 80°C									
Conductor/ Metallic screen	DC 20°C	AC 90°C	DC 20°C	AC 80°C									
mm <sup>2</sup>	Ω/km				kV/mm	Ω/km	Ω/km	μF/km	kΩ/km	A/km	mH/km	Ω/km	Ω/km
1x630RMC/50											0.33	0.103	0.120
											0.53	0.167	0.178
											0.51	0.161	0.173
1x800RMC/50											0.32	0.100	0.112
											0.51	0.161	0.169
											0.50	0.158	0.166
1x1000RMC/50											0.31	0.096	0.105
											0.49	0.155	0.160
											0.49	0.154	0.160

## Current – carrying capacity

Nominal cross sectional area	Max short circuit capacity	GROUND				AIR					
		FLAT		TREFOIL		FLAT		TREFOIL			
		Conductor	Metallic screen	BE	SPB, CB	BE	SPB, CB	BE	SPB, CB	BE	SPB, CB
mm <sup>2</sup>	kA/sec	A									
1x50RMC/16	4.7	3.7	220	222	210	210	231	233	203	203	
1x70RMC/25	6.6	5.3	268	272	257	257	285	288	250	251	
1x95RMC/35	9.0	7.1	319	328	308	310	344	352	304	305	
1x120RMC/50	11.3	9.8	359	374	351	354	390	405	348	350	
1x150RMC/50	14.2	9.8	401	422	394	399	441	462	395	399	
1x185RMC/50	17.5	9.8	449	480	447	453	501	531	452	457	
1x240RMC/50	22.7	9.8	512	559	518	528	581	626	530	539	
1x300RMC/50	28.4	9.8	568	634	585	598	655	720	605	617	
1x400RMC/50	37.8	9.8	636	732	670	689	748	844	703	722	
1x500RMC/50	47.3	9.8	705	840	761	789	845	982	812	838	
1x630RMC/50	59.5	9.8	779	966	864	905	953	1149	938	977	
1x800RMC/50	75.6	9.8	849	1102	968	1025	1060	1331	1069	1124	
1x1000RMC/50	94.5	9.8	919	1248	1075	1152	1169	1538	1209	1286	

## Operating Conditions

For laying in ground		For installation in air	
Depth of lay:	0,7 m.	Ambient temperature:	30°C
Ground temperature:	20°C	Protection from direct solar radiation	
Soil thermal resistivity:	1/ 2,5 K · m/W		

# MEDIUM VOLTAGE XLPE POWER CABLES – Longitudinally and Radially Sealed

## 18/30 (36) kV

64

COPPER CONDUCTOR - Round, stranded and compacted conductor - Class 2  
XRUHKXS acc. ZN-TF-501:2002  
2XS(FL)2Y acc. to IEC 60502-2:2005 and BS 6622:2007  
N2XS(FL)2Y acc. to DIN VDE 0276-620 and HD 620S2:2010 part 10 section C

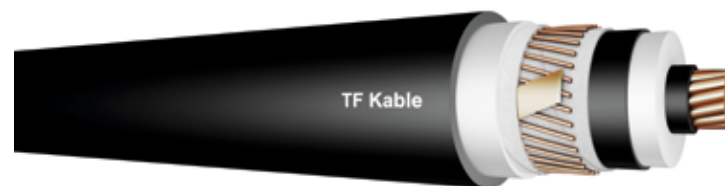

Conductor – nominal cross sectional area	Conductor diameter	Insulation		Metallic screen		Cable diameter D <sub>e</sub>	Cable weight	Maximum cable pulling force	Recommended min. bending radius for laying
		Thickness	Diameter over insulation	Cross sectional area	Diameter over metallic screen				
mm <sup>2</sup>	mm			mm <sup>2</sup>	mm	mm	kg/km	kN	m
1x35RMC	7.0 <sup>+0.15</sup>	8.0	24.2	16	28.3	34.3	1210	1.75	0.74
1x50RMC	8.25 <sup>+0.20</sup>	8.0	25.5	16	29.5	35.6	1370	2.5	0.78
1x70RMC	9.6 <sup>+0.20</sup>	8.0	26.8	25	30.9	36.9	1690	3.5	0.81
1x95RMC	11.5 <sup>+0.20</sup>	8.0	28.7	35	32.8	38.8	2080	4.75	0.86
1x120RMC	12.9 <sup>+0.25</sup>	8.0	30.1	50	34.2	40.2	2490	6	0.89
1x150RMC	14.5 <sup>+0.30</sup>	8.0	31.7	50	35.8	41.8	2790	7.5	0.93
1x185RMC	16.0 <sup>+0.30</sup>	8.0	33.2	50	37.3	43.3	3170	9.25	0.97
1x240RMC	18.5 <sup>+0.30</sup>	8.0	35.7	50	39.8	45.8	3750	12	1.03
1x300RMC	20.5 <sup>+0.30</sup>	8.0	37.7	50	41.8	47.8	4360	15	1.08
1x400RMC	23.5 <sup>+0.30</sup>	8.0	40.7	50	44.8	51.0	5270	20	1.16
1x500RMC	26.5 <sup>+0.40</sup>	8.0	44.2	50	48.5	54.9	6440	25	1.25
1x630RMC	30.3 <sup>+0.40</sup>	8.0	48.3	50	52.5	59.4	7860	31.5	1.35
1x800RMC	34.6 <sup>+0.50</sup>	8.0	53.0	50	57.2	64.5	9620	40	1.47
1x1000RMC	38.2 <sup>+0.40</sup>	8.0	56.6	50	60.8	68.3	11570	50	1.56

# Electrical data

RM (RMC) - Round Multiwire Conductor IC (C - compacted), Class 2  
 SPB - Single Point Bonded  
 CB - Cross Bonded  
 BE - Both Ends  
 D<sub>e</sub> - Cable diameter

2 - Cables in trefoil formation, the distance between cables D<sub>e</sub>  
 3 - Cables in flat formation (in the ground) – the distance between cables D<sub>e</sub> + 70 mm  
 4 - Cables in flat formation (in the air) – the distance between cables 2 x D<sub>e</sub>

Nominal cross sectional area	Conductor resistance		Metallic screen resistance		Electrical field stress at conductor/insulation	Zero resistance R <sub>0</sub>	Zero reactance X <sub>0</sub>	Capacitance C	Capacitive reactance X <sub>c</sub>	Charging current I <sub>c</sub>	Inductance L	Inductive reactance XI	Impedance
	DC 20°C	AC 90°C	DC 20°C	AC 80°C							o <sup>0</sup> o <sup>2</sup>	o <sup>0</sup> o <sup>2</sup>	o <sup>0</sup> o <sup>2</sup>
Conductor/Metallic screen											ooo <sup>3</sup>	ooo <sup>3</sup>	ooo <sup>3</sup>
mm <sup>2</sup>	Ω/km				kV/mm	Ω/km	Ω/km	μF/km	kΩ/km	A/km	mH/km	Ω/km	Ω/km
1x35RMC/16	0.524	0.668	1.12	1.38	4.07/1.34	1.41	0.103	0.12	27.6	0.65	0.51	0.159	0.687
											0.78	0.244	0.711
											0.69	0.217	0.703
1x50RMC/16	0.387	0.494	1.12	1.38	3.85/1.40	1.22	0.095	0.13	25.2	0.71	0.48	0.151	0.516
											0.74	0.234	0.546
											0.67	0.209	0.536
1x70RMC/25	0.268	0.342	0.72	0.89	3.66/1.45	0.89	0.088	0.14	23.1	0.78	0.46	0.144	0.371
											0.72	0.225	0.410
											0.64	0.202	0.397
1x95RMC/35	0.193	0.247	0.51	0.63	3.47/1.51	0.68	0.081	0.15	20.7	0.87	0.43	0.136	0.281
											0.68	0.215	0.327
											0.62	0.194	0.314
1x120RMC/50	0.153	0.196	0.36	0.44	3.35/1.55	0.53	0.076	0.17	19.2	0.94	0.42	0.131	0.235
											0.66	0.209	0.286
											0.60	0.189	0.272
1x150RMC/50	0.124	0.159	0.36	0.44	3.25/1.59	0.49	0.072	0.18	17.8	1.01	0.40	0.126	0.203
											0.64	0.202	0.257
											0.59	0.184	0.243
1x185RMC/50	0.0991	0.127	0.36	0.44	3.16/1.62	0.46	0.068	0.19	16.7	1.08	0.39	0.122	0.176
											0.63	0.197	0.234
											0.57	0.180	0.220
1x240RMC/50	0.0754	0.0976	0.36	0.44	3.05/1.67	0.42	0.063	0.21	15.1	1.19	0.37	0.116	0.152
											0.60	0.189	0.213
											0.55	0.174	0.200
1x300RMC/50	0.0601	0.0785	0.36	0.44	2.98/1.70	0.40	0.060	0.23	14.0	1.29	0.36	0.112	0.137
											0.58	0.184	0.200
											0.54	0.171	0.188

Nominal cross sectional area	Conductor resistance		Metallic screen resistance		Electrical field stress at conductor/insulation	Zero resistance $R_0$	Zero reactance $X_0$	Capacitance $C$	Capacitive reactance $X_c$	Charging current $I_c$	Inductance $L$	Inductive reactance $X_l$	Impedance
	DC 20°C	AC 90°C	DC 20°C	AC 80°C							$0^0 0^2$	$0^0 0^2$	$0^0 0^2$
Conductor/ Metallic screen	DC 20°C	AC 90°C	DC 20°C	AC 80°C							$000^3$	$000^3$	$000^3$
mm <sup>2</sup>	Ω/km				kV/mm	Ω/km	Ω/km	μF/km	kΩ/km	A/km	mH/km	Ω/km	Ω/km
											0.34	0.108	0.125
1x400RMC/50	0.0470	0.0625	0.36	0.44	2.90/1.74	0.38	0.056	0.25	12.6	1.42	0.56	0.177	0.187
											0.53	0.166	0.177
											0.33	0.105	0.116
1x500RMC/50	0.0366	0.0499	0.36	0.44	2.80/1.77	0.36	0.053	0.28	11.5	1.57	0.54	0.171	0.178
											0.52	0.163	0.171
											0.32	0.102	0.109
1x630RMC/50	0.0283	0.0403	0.36	0.44	2.73/1.81	0.34	0.050	0.31	10.3	1.75	0.53	0.165	0.170
											0.51	0.160	0.165
											0.31	0.098	0.104
1x800RMC/50	0.0221	0.0334	0.36	0.44	2.67/1.85	0.33	0.047	0.35	9.2	1.97	0.51	0.159	0.163
											0.50	0.156	0.160
											0.30	0.096	0.100
1x1000RMC/50	0.0176	0.0287	0.36	0.44	2.63/1.87	0.32	0.045	0.38	8.5	2.13	0.49	0.155	0.157
											0.49	0.154	0.156

## Current – carrying capacity

Nominal cross sectional area	Max short circuit capacity		GROUND				AIR			
			FLAT		TREFOIL		FLAT		TREFOIL	
	Conductor	Metallic screen	BE	SPB, CB	BE	SPB, CB	BE	SPB, CB	BE	SPB, CB
mm <sup>2</sup>	kA/sec		A							
1x35RMC/16	5.0	3.7	238	241	228	228	248	250	219	219
1x50RMC/16	7.2	3.7	282	286	271	272	297	301	262	262
1x70RMC/25	10.0	5.3	342	351	331	332	364	372	323	324
1x95RMC/35	13.6	7.1	406	424	397	401	439	456	392	395
1x120RMC/50	17.2	9.8	450	483	451	457	495	525	448	454
1x150RMC/50	21.5	9.8	499	546	506	515	556	599	509	517
1x185RMC/50	26.5	9.8	552	618	571	584	625	685	578	590
1x240RMC/50	34.3	9.8	623	723	661	680	721	813	679	697
1x300RMC/50	42.9	9.8	683	820	743	770	804	932	771	797
1x400RMC/50	57.2	9.8	753	940	841	881	905	1087	887	924
1x500RMC/50	71.5	9.8	821	1073	945	999	1006	1259	1013	1066

Nominal cross sectional area	Max short circuit capacity		GROUND				AIR			
	Conductor	Metallic screen	FLAT		TREFOIL		FLAT		TREFOIL	
			BE	SPB, CB	BE	SPB, CB	BE	SPB, CB	BE	SPB, CB
<b>mm<sup>2</sup></b>	<b>kA/sec</b>		<b>A</b>							
1x630RMC/50	90.1	9.8	894	1226	1058	1134	1116	1464	1155	1229
1x800RMC/50	114.4	9.8	959	1386	1165	1267	1220	1684	1298	1398
1x1000RMC/50	143.0	9.8	1014	1534	1260	1389	1306	1894	1423	1552

## Operating Conditions

For laying in ground		For installation in air	
Depth of lay:	0,7 m.	Ambient temperature:	30°C
Ground temperature:	20°C	Protection from direct solar radiation	
Soil thermal resistivity:	1/ 2,5 K · m/W		

# High-Voltage Cables

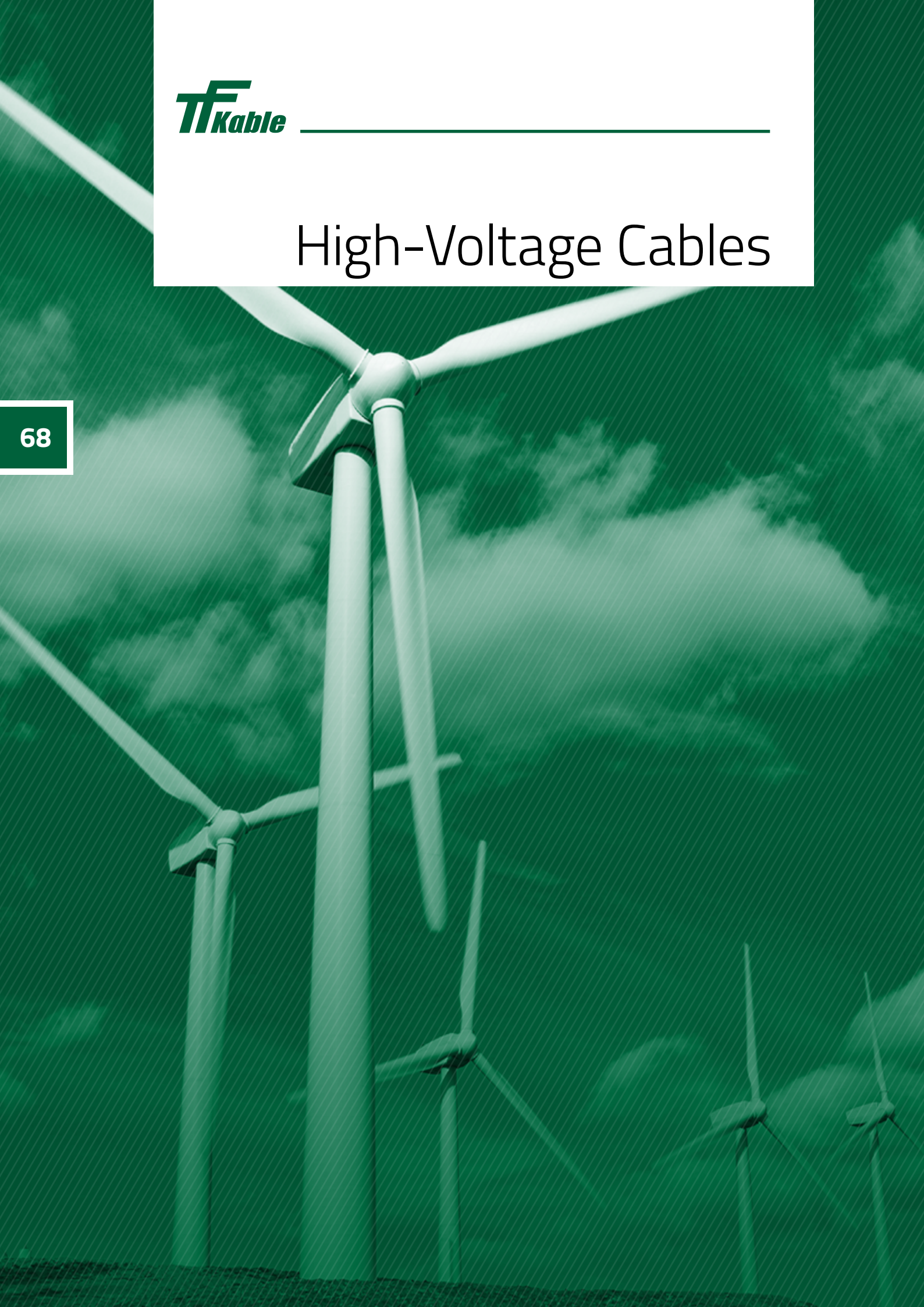

# Table of Contents

HIGH-VOLTAGE XLPE CABLES	72
HIGH-VOLTAGE XLPE CABLES	74
HIGH-VOLTAGE XLPE CABLES	76
HIGH-VOLTAGE XLPE CABLES	78
HIGH-VOLTAGE XLPE CABLES	80
HIGH-VOLTAGE XLPE CABLES	82
HIGH-VOLTAGE XLPE CABLES	84
HIGH-VOLTAGE XLPE CABLES	86
HIGH-VOLTAGE XLPE CABLES	88
HIGH-VOLTAGE XLPE CABLES	90
HIGH-VOLTAGE XLPE CABLES	92
HIGH-VOLTAGE XLPE CABLES	94
HIGH-VOLTAGE XLPE CABLES	96

# TYPES OF CABLES

Cable constructions are shown in the following figures:

**Figure 1** : XRUHAKXS, XRUHKXS – NA2XS(FL)2Y, N2XS(-FL)2Y.

### Description of Figure 1

- 1 – Aluminium or copper conductor
- 2 – Semi-conductive screen extruded on the phase conductor
- 3 – XLPE insulation
- 4 – Semi-conductive screen extruded on insulation
- 5 – Wrapping of semi-conductive water swelling tape
- 6 – Metallic screen
- 7 – Wrapping of semi-conductive water swelling tape
- 8 – Longitudinally applied aluminium tape coated with PE copolymer
- 9 – HDPE / MDPE outer sheath



For unusual applications TELE-FONIKA Kable offers you the single-core cables:

**Figure 2**: YHAKXS, YHKXS – NA2XS2Y, N2XS2Y – XHAKXS, XHKXS – NA2XS2Y, N2XS2Y, NHAKXS, NHKXS – NA2XSH, N2XSH.

### Description of Figure 2

- 1 – Aluminium or copper conductor
- 2 – Semi-conductive screen extruded on the phase conductor
- 3 – XLPE insulation
- 4 – Semi-conductive screen extruded on insulation
- 5 – Semi-conductive tape wrap, non swelling under action of water
- 6 – Metallic screen
- 7 – Wrapping of polyester tape
- 8 – Outer sheath: PVC, HDPE / MDPE, LSF



**Figure 3:** XUHAKXS, XUHKXS – NA2XS(F)2Y, N2XS(F)2Y, NUHAKXS, NUHKXS – NA2XS(F)H, N2XS(F)H.

**Description of Figure 3**

- 1 – Aluminium or copper conductor
- 2 – Semi-conductive screen extruded on the phase conductor
- 3 – XLPE insulation
- 4 – Semi-conductive screen extruded on insulation
- 5 – Wrapping of semi-conductive water swelling tape
- 6 – Metallic screen
- 7 – Wrapping of non conductive water swelling tape
- 8 – Outer sheath: PVC, HDPE / MDPE, LSF

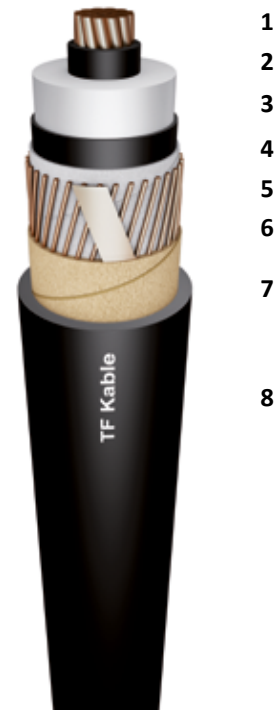

**Milliken design conductors are applied for cables conductors with cross-sections > 1000 mm<sup>2</sup>**



**Selection of cable**

High voltage cables are manufactured based on customer specifications and factory standards.

Cable structures are based on the requirements of IEC standards:

- IEC 60287 – Calculation of current-carrying capacity of cables (load factor 100%)
- IEC 60853 – Calculation of current-carrying capacity of cables for cyclic load or fault conditions
- IEC 61443 – Maximum short circuit temperature for cables for voltages above 30kV
- IEC 60228 – Conductors of wires and cables

When selecting cable, specialized software is used to simulate the cable system operation.

**Calculation basis**

**In the soil** – the temperature of 20°C, cabling depth 1.0 m, soil thermal resistivity  $K = 1.0 \text{ Km/W}$ , the distance between phases =  $2xD$ .

For cables laid in separate cable culverts the load capacity (current-carrying capacity) is reduced to 90% of values presented in the tables.

**In the air** – the temperature of 35°C

**Terms of cabling**

Minimum temperature of laying cable: -20°C for cables < 110 kV and -5°C for cables  $\geq 110 \text{ kV}$  provided they are soaked immediately before laying (detailed information can be found in the guidelines for laying MV and HV cables).

Minimum bend radius: a value in meters is given in the tables

The maximum pulling force for the working conductor or with cable grip on external shell: the value in kN is given in the tables.

The minimum diameter of casing pipes:  $\text{min. } 1.5 \times D \text{ (mm)}$ , where  $D = \text{external diameter of cable in mm}$ .

# HIGH-VOLTAGE XLPE CABLES

## 36/60÷69(72.5) kV

COPPER CONDUCTOR

N2XS(FL)2Y according to DIN VDE 0276-632

2XS(FL)2Y according to IEC 60840

XRUHKXS according to ZN-TF-530:2009; IEC 60840

72

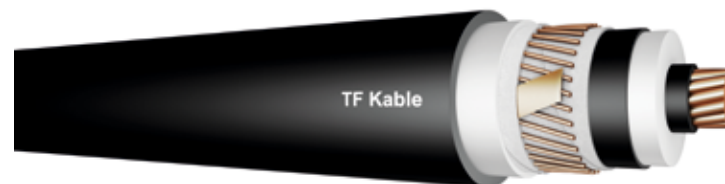

Cross section of conductor*	Diameter of conductor	Insulation		Metallic screen		D <sub>e</sub> Outer diameter of cable	Cable weight	Maximum pulling force	Minimal bending radius
		Nominal thickness	Diameter over insulation	Cross section	Diameter over screen				
mm <sup>2</sup>	mm	mm		mm <sup>2</sup>		mm	kg/km	kN	m
1 x 120RM	12.9 <sup>+ 0.25</sup>	13	40.1	35	44.3	51.3	3080	6.0	1.01
1 x 150RM	14.5 <sup>+ 0.30</sup>	12	39.7	35	43.9	50.9	3270	7.5	1.00
1 x 185RM	16.0 <sup>+ 0.30</sup>	12	41.2	35	45.4	52.4	3670	9.3	1.03
1 x 240RM	18.5 <sup>+ 0.30</sup>	11	41.7	35	45.9	53.1	4150	12.0	1.04
1 x 300RM	20.5 <sup>+ 0.30</sup>	11	43.7	35	47.9	55.1	4780	15.0	1.09
1 x 400RM	23.5 <sup>+ 0.30</sup>	11	47.1	35	51.7	59.3	5820	20.0	1.17
1 x 500RM	26.5 <sup>+ 0.40</sup>	10	48.1	35	52.7	60.3	6770	25.0	1.19
1 x 630RM	30.3 <sup>+ 0.40</sup>	10	52.2	35	56.8	64.5	8220	31.5	1.28
1 x 800RM	34.6 <sup>+ 0.50</sup>	10	56.5	35	61.1	69.2	9990	40.0	1.38
1 x 1000RM	38.2 <sup>+ 0.40</sup>	10	60.5	50	65.5	73.8	12210	50.0	1.47
1 x 1200RMS	43.6 <sup>+ 0.80</sup>	10	67.6	50	72.6	81.6	14610	60.0	1.63
1 x 1400RMS	46.6 <sup>+ 1.00</sup>	10	70.6	50	75.6	84.8	16570	70.0	1.70
1 x 1600RMS	50.0 <sup>+ 1.00</sup>	10	74.0	50	79.0	88.5	18570	80.0	1.77
1 x 1800RMS	53.3 <sup>+ 1.00</sup>	9	77.3	50	82.3	92.0	20560	90.0	1.84
1 x 2000RMS	56.3 <sup>+ 1.20</sup>	10	80.3	50	85.3	95.2	22600	100.0	1.91

\*production range up to 3000 mm<sup>2</sup>; cable data for sections >2000 mm<sup>2</sup> are available on request

# Electrical data

RM (RMC) - Round Multiwire Conductor (C - compacted), Class 2  
 RMS (Milliken type) – Round Multiwire Segmented Conductor  
 SPB - Single Point Bonded  
 CB - Cross Bonded

BE - Both Ends  
 $D_e$  - Cable diameter  
 1 - Cables in flat formation, the distance between cables  $2 \times D_e$   
 2 - Cables in trefoil formation, the distance between cables  $D_e$

Cross section of conductor	Resistance of conductor		Resistance of metallic screen		Electric field strength at the Conductor screen / insulation	Short-circuit current-carrying capacity		Capacitance	Inductance	Current-carrying capacity			
	DC 20°C	AC 90°C	DC 20°C	AC 80°C		Conductor	Metallic screen			000 <sup>1</sup>	0 <sup>0</sup> 0 <sup>2</sup>	In ground	In air
												SPB,CB / BE	SPB,CB / BE
mm <sup>2</sup>	Ω/km				kV/mm	kA/1sec.		μF/km	mH/km	A			
1 x 120RM	0.1530	0.1956	0.542	0.670	5.17 / 1.82	17.5	7.4	0.122	0.649	388 / 364	467 / 449		
									0.465	370 / 367	414 / 411		
1 x 150RM	0.1240	0.1588	0.542	0.670	5.23 / 2.07	21.8	7.4	0.138	0.624	436 / 403	534 / 507		
									0.440	416 / 411	470 / 466		
1 x 185RM	0.0991	0.1273	0.542	0.670	5.07 / 2.12	26.9	7.4	0.146	0.611	493 / 447	610 / 572		
									0.426	469 / 462	535 / 529		
1 x 240RM	0.0754	0.0974	0.542	0.670	5.16 / 2.44	34.8	7.4	0.170	0.584	574 / 504	725 / 664		
									0.399	545 / 534	631 / 621		
1 x 300RM	0.0601	0.0783	0.542	0.670	5.02 / 2.49	43.5	7.4	0.183	0.571	648 / 553	831 / 744		
									0.386	614 / 599	721 / 707		
1 x 400RM	0.0470	0.0620	0.542	0.670	4.82 / 2.57	57.9	7.4	0.203	0.558	741 / 607	965 / 839		
									0.374	698 / 676	835 / 814		
1 x 500RM	0.0366	0.0491	0.542	0.670	5.05 / 2.95	72.2	7.4	0.238	0.538	845 / 663	1125 / 942		
									0.353	791 / 760	963 / 933		
1 x 630RM	0.0283	0.0389	0.542	0.670	4.90 / 3.02	90.9	7.4	0.264	0.525	974 / 707	1308 / 1051		
									0.340	894 / 850	1112 / 1067		
1 x 800RM	0.0221	0.0313	0.542	0.670	4.78 / 3.09	115.4	7.4	0.292	0.512	1082 / 765	1505 / 1155		
									0.327	998 / 938	1266 / 1204		
1 x 1000RM	0.0176	0.0260	0.379	0.468	4.69 / 3.14	144.1	10.5	0.318	0.505	1197 / 759	1684 / 1189		
									0.320	1082 / 994	1398 / 1306		
1 x 1200RMS	0.0151	0.0203	0.379	0.468	4.56 / 3.21	172.8	10.5	0.364	0.499	1385 / 802	1981 / 1303		
									0.314	1258 / 1127	1663 / 1552		
1 x 1400RMS	0.0129	0.0176	0.379	0.468	4.52 / 3.24	201.5	10.5	0.384	0.493	1496 / 824	2166 / 1360		
									0.308	1346 / 1189	1804 / 1632		
1 x 1600RMS	0.0113	0.0156	0.379	0.468	4.48 / 3.27	230.3	10.5	0.406	0.488	1596 / 841	2340 / 1411		
									0.303	1424 / 1242	1933 / 1730		
1 x 1800RMS	0.0101	0.0141	0.379	0.468	4.44 / 3.29	259.0	10.5	0.427	0.483	1685 / 855	2499 / 1456		
									0.298	1490 / 1286	2047 / 1816		
1 x 2000RMS	0.0090	0.0128	0.379	0.468	4.41 / 3.31	287.7	10.5	0.446	0.478	1775 / 868	2659 / 1497		
									0.294	1556 / 1329	2160 / 1898		

# HIGH-VOLTAGE XLPE CABLES

## 36/60÷69(72.5) kV

ALUMINIUM CONDUCTOR

NA2XS(FL)2Y according to DIN VDE 0276-632

A2XS(FL)2Y according to IEC 60840

XRUHAKXS according to ZN-TF-530:2009; IEC 60840

74

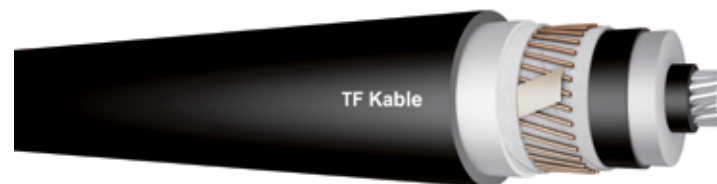

Cross section of conductor*	Diameter of conductor	Insulation		Metallic screen		D <sub>e</sub> Outer diameter of cable	Cable weight	Maximum pulling force	Minimal bending radius
		Nominal thickness	Diameter over insulation	Cross section	Diameter over screen				
mm <sup>2</sup>	mm	mm		mm <sup>2</sup>		mm	kg/km	kN	m
1 x 120RM	12.5 <sup>+ 0.2°</sup>	13	39.7	35	43.9	50.9	2340	3.6	1.00
1 x 150RM	14.2 <sup>+ 0.2°</sup>	12	39.4	35	43.6	50.6	2360	4.5	0.99
1 x 185RM	15.8 <sup>+ 0.2°</sup>	12	41.0	35	45.2	52.2	2540	5.6	1.03
1 x 240RM	17.9 <sup>+ 0.1°</sup>	11	41.1	35	45.3	52.3	2640	7.2	1.03
1 x 300RM	20.0 <sup>+ 0.3°</sup>	11	43.2	35	47.4	54.6	2910	9.0	1.07
1 x 400RM	22.9 <sup>+ 0.3°</sup>	11	46.5	35	51.1	58.5	3370	12.0	1.16
1 x 500RM	25.7 <sup>+ 0.4°</sup>	10	47.3	35	51.9	59.5	3650	15.0	1.17
1 x 630RM	29.3 <sup>+ 0.5°</sup>	10	51.2	35	55.8	63.5	4230	18.9	1.26
1 x 800RM	33.0 <sup>+ 0.5°</sup>	10	54.9	35	59.5	67.4	4870	24.0	1.34
1 x 1000RM	38.0 <sup>+ 0.5°</sup>	10	60.3	50	65.3	73.6	5960	30.0	1.47
1 x 1200RM	41.0 <sup>+ 0.6°</sup>	10	63.3	50	68.3	76.8	6740	36.0	1.53
1 x 1200RMS	43.6 <sup>+ 0.8°</sup>	10	67.6	50	72.6	81.6	7160	36.0	1.63
1 x 1400RMS	46.6 <sup>+ 1.0°</sup>	10	70.6	50	75.6	84.8	7890	42.0	1.70
1 x 1600RMS	50.0 <sup>+ 1.0°</sup>	10	74.0	50	79.0	88.5	8650	48.0	1.77
1 x 1800RMS	53.3 <sup>+ 1.0°</sup>	10	77.3	50	82.3	92.0	9420	54.0	1.84
1 x 2000RMS	55.4 <sup>+ 1.0°</sup>	10	79.4	50	84.4	94.3	10090	60.0	1.89

\*production range up to 3000 mm<sup>2</sup>; cable data for sections >2000 mm<sup>2</sup> are available on request

# Electrical data

RM (RMC) - Round Multiwire Conductor (C - compacted), Class 2  
 RMS (Milliken type) – Round Multiwire Segmented Conductor  
 SPB - Single Point Bonded  
 CB - Cross Bonded

BE - Both Ends  
 $D_e$  - Cable diameter  
 1 - Cables in flat formation, the distance between cables  $2 \times D_e$   
 2 - Cables in trefoil formation, the distance between cables  $D_e$

Cross section of conductor	Resistance of conductor		Resistance of metallic screen		Electric field strength at the Conductor screen / insulation	Short-circuit current-carrying capacity		Capacitance	Inductance	Current-carrying capacity		
	DC 20°C	AC 90°C	DC 20°C	AC 80°C		Conductor	Metallic screen			ooo <sup>1</sup>	In ground	In air
											ooo <sup>1</sup>	ooo <sup>2</sup>
mm <sup>2</sup>	Ω/km				kV/mm	kA/1sec.		μF/km	mH/km	A		
1 x 120RM	0.2530	0.3247	0.542	0.670	5.23 / 1.80	11.6	7.4	0.120	0.654	300 / 288	360 / 351	
									0.469	286 / 285	320 / 318	
1 x 150RM	0.2060	0.2645	0.542	0.670	5.27 / 2.06	14.5	7.4	0.136	0.627	338 / 321	412 / 399	
									0.443	322 / 319	363 / 361	
1 x 185RM	0.1640	0.2108	0.542	0.670	5.09 / 2.11	17.8	7.4	0.145	0.612	382 / 360	473 / 454	
									0.427	364 / 361	415 / 412	
1 x 240RM	0.1250	0.1610	0.542	0.670	5.21 / 2.42	23.1	7.4	0.167	0.588	444 / 410	560 / 529	
									0.403	422 / 417	488 / 483	
1 x 300RM	0.1000	0.1292	0.542	0.670	5.05 / 2.48	28.8	7.4	0.180	0.574	503 / 454	642 / 599	
									0.389	477 / 470	559 / 552	
1 x 400RM	0.0778	0.1011	0.542	0.670	4.85 / 2.56	38.3	7.4	0.199	0.561	578 / 508	750 / 686	
									0.376	547 / 536	652 / 642	
1 x 500RM	0.0605	0.0794	0.542	0.670	5.08 / 2.93	47.8	7.4	0.232	0.541	663 / 562	878 / 781	
									0.356	625 / 609	757 / 741	
1 x 630RM	0.0469	0.0624	0.542	0.670	4.93 / 3.00	60.2	7.4	0.258	0.528	761 / 619	1027 / 885	
									0.343	714 / 690	881 / 858	
1 x 800RM	0.0367	0.0497	0.542	0.670	4.82 / 3.06	76.4	7.4	0.282	0.516	865 / 672	1190 / 989	
									0.332	806 / 774	1015 / 982	
1 x 1000RM	0.0291	0.0402	0.379	0.468	4.69 / 3.14	95.3	10.5	0.317	0.506	975 / 691	1368 / 1060	
									0.321	898 / 845	1157 / 1102	
1 x 1200RM	0.0247	0.0347	0.379	0.468	4.64 / 3.17	114.3	10.5	0.336	0.499	1056 / 719	1501 / 1123	
									0.314	963 / 900	1259 / 1192	
1 x 1200RMS	0.0247	0.0322	0.379	0.468	4.56 / 3.21	114.3	10.5	0.364	0.499	1121 / 740	1601 / 1173	
									0.314	1034 / 957	1362 / 1281	
1 x 1400RMS	0.0212	0.0278	0.379	0.468	4.52 / 3.24	133.3	10.5	0.384	0.493	1218 / 767	1759 / 1238	
									0.308	1115 / 1021	1489 / 1387	
1 x 1600RMS	0.0186	0.0245	0.379	0.468	4.48 / 3.27	152.3	10.5	0.406	0.488	1310 / 789	1915 / 1297	
									0.303	1192 / 1079	1612 / 1488	
1 x 1800RMS	0.0165	0.0218	0.379	0.468	4.44 / 3.29	171.2	10.5	0.427	0.483	1397 / 808	2065 / 1350	
									0.298	1263 / 1131	1728 / 1581	
1 x 2000RMS	0.0149	0.0198	0.379	0.468	4.42 / 3.31	190.2	10.5	0.440	0.480	1473 / 824	2195 / 1390	
									0.295	1324 / 1174	1827 / 1658	

# HIGH-VOLTAGE XLPE CABLES

## 64/110 ÷ 115(123) kV

COPPER CONDUCTOR

N2XS(FL)2Y according to DIN VDE 0276-632

2XS(FL)2Y according to IEC 60840

XRUHKXS according to ZN-TF-530:2009; IEC 60840

76

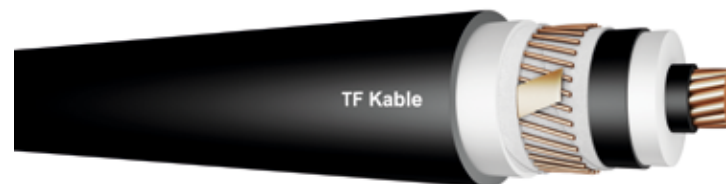

Cross section of conductor*	Diameter of conductor	Insulation		Metallic screen		D <sub>e</sub> Outer diameter of cable	Cable weight	Maximum pulling force	Minimal bending radius
		Nominal thickness	Diameter over insulation	Cross section	Diameter over screen				
mm <sup>2</sup>	mm	mm		mm <sup>2</sup>		mm	kg/km	kN	m
1 x 150RM	14.5 <sup>+0.3°</sup>	17	51.5	95	57.3	65.3	5080	7.5	1.29
1 x 185RM	16.0 <sup>+0.3°</sup>	17	52.4	95	58.2	66.2	5450	9.3	1.31
1 x 240RM	18.5 <sup>+0.3°</sup>	16	52.5	95	58.3	66.3	5890	12.0	1.31
1 x 300RM	20.5 <sup>+0.3°</sup>	15	52.5	95	58.3	66.3	6370	15.0	1.31
1 x 400RM	23.5 <sup>+0.3°</sup>	15	55.5	95	61.3	69.5	7380	20.0	1.38
1 x 500RM	26.5 <sup>+0.4°</sup>	15	58.5	95	64.3	72.7	8560	25.0	1.45
1 x 630RM	30.3 <sup>+0.4°</sup>	15	63.0	95	68.8	77.5	10160	31.5	1.55
1 x 800RM	34.6 <sup>+0.5°</sup>	15	67.3	95	73.1	82.0	11980	40.0	1.64
1 x 1000RM	38.2 <sup>+0.4°</sup>	15	70.9	95	76.7	85.8	14030	50.0	1.72
1 x 1200RMS	43.6 <sup>+0.8°</sup>	15	77.6	95	83.4	93.3	16520	60.0	1.87
1 x 1400RMS	46.6 <sup>+1.0°</sup>	15	80.6	95	86.4	96.5	18530	70.0	1.93
1 x 1600RMS	50.0 <sup>+1.0°</sup>	15	84.0	95	89.8	100.1	20580	80.0	2.01
1 x 1800RMS	53.3 <sup>+1.0°</sup>	15	87.3	95	93.1	103.6	22630	90.0	2.08
1 x 2000RMS	56.3 <sup>+1.2°</sup>	15	90.3	95	96.1	106.8	24720	100.0	2.15

\*production range up to 3000 mm<sup>2</sup>; cable data for sections >2000 mm<sup>2</sup> are available on request

# Electrical data

RM (RMC) - Round Multiwire Conductor (C - compacted), Class 2  
 RMS (Milliken type) – Round Multiwire Segmented Conductor  
 SPB - Single Point Bonded  
 CB - Cross Bonded

BE - Both Ends  
 $D_e$  - Cable diameter  
 1 - Cables in flat formation, the distance between cables  $2 \times D_e$   
 2 - Cables in trefoil formation, the distance between cables  $D_e$

Cross section of conductor	Resistance of conductor		Resistance of metallic screen		Electric field strength at the Conductor screen / insulation	Short-circuit current-carrying capacity		Capacitance	Inductance	Current-carrying capacity	
	DC 20°C	AC 90°C	DC 20°C	AC 80°C		Conductor	Metallic screen			In ground	In air
mm <sup>2</sup>	Ω/km				kV/mm	kA/1sec.		μF/km	mH/km	A	
1 x 150RM	0.1240	0.1587	0.200	0.247	6.72 / 2.28	21.8	19.0	0.118	0.674	434 / 384	521 / 486
										0.489	413 / 404
1 x 185RM	0.0991	0.1272	0.200	0.247	6.60 / 2.32	26.9	19.0	0.122	0.657	490 / 422	595 / 546
										0.473	465 / 453
1 x 240RM	0.0754	0.0973	0.200	0.247	6.59 / 2.57	34.8	19.0	0.136	0.629	570 / 470	707 / 628
										0.444	539 / 520
1 x 300RM	0.0601	0.0781	0.200	0.247	6.66 / 2.86	43.5	19.0	0.151	0.608	644 / 510	811 / 699
										0.423	607 / 580
1 x 400RM	0.0470	0.0618	0.200	0.247	6.40 / 2.94	57.9	19.0	0.164	0.590	736 / 553	943 / 783
										0.405	690 / 652
1 x 500RM	0.0366	0.0489	0.200	0.247	6.20 / 3.02	72.2	19.0	0.178	0.575	838 / 595	1091 / 869
										0.390	780 / 728
1 x 630RM	0.0283	0.0387	0.200	0.247	5.95 / 3.12	90.9	19.0	0.198	0.561	946 / 641	1264 / 959
										0.377	880 / 808
1 x 800RM	0.0221	0.0312	0.200	0.247	5.77 / 3.20	115.4	19.0	0.216	0.546	1074 / 682	1452 / 1046
										0.361	980 / 885
1 x 1000RM	0.0176	0.0259	0.200	0.247	5.65 / 3.26	144.1	19.0	0.232	0.535	1185 / 701	1628 / 1118
										0.351	1069 / 951
1 x 1200RMS	0.0151	0.0202	0.200	0.247	5.46 / 3.35	172.8	19.0	0.261	0.526	1366 / 738	1910 / 1218
										0.341	1232 / 1062
1 x 1400RMS	0.0129	0.0175	0.200	0.247	5.39 / 3.39	201.5	19.0	0.274	0.519	1462 / 763	2085 / 1272
										0.334	1316 / 1116
1 x 1600RMS	0.0113	0.0155	0.200	0.247	5.32 / 3.42	230.3	19.0	0.289	0.512	1572 / 772	2250 / 1390
										0.327	1389 / 1162
1 x 1800RMS	0.0101	0.0140	0.200	0.247	5.26 / 3.46	259.0	19.0	0.303	0.506	1658 / 785	2400 / 1360
										0.321	1452 / 1200
1 x 2000RMS	0.0090	0.0127	0.200	0.247	5.22 / 3.48	287.7	19.0	0.316	0.501	1699 / 812	2552 / 1396
										0.317	1513 / 1235

# HIGH-VOLTAGE XLPE CABLES

## 64/110 ÷ 115(123) kV

ALUMINIUM CONDUCTOR

NA2XS(FL)2Y according to DIN VDE 0276-632

A2XS(FL)2Y according to IEC 60840

XRUHAKXS according to ZN-TF-530:2009; IEC 60840

78

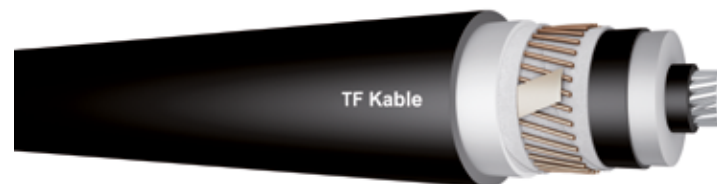

Cross section of conductor*	Diameter of conductor	Insulation		Metallic screen		D <sub>e</sub> Outer diameter of cable	Cable weight	Maximum pulling force	Minimal bending radius
		Nominal thickness	Diameter over insulation	Cross section	Diameter over screen				
mm <sup>2</sup>	mm	mm		mm <sup>2</sup>		mm	kg/km	kN	m
1 x 150RM	14.2 <sup>+ 0.2°</sup>	17	51.2	95	57.0	64.8	4150	4.5	1.29
1 x 185RM	15.8 <sup>+ 0.2°</sup>	17	52.2	95	58.0	66.0	4320	5.6	1.31
1 x 240RM	17.9 <sup>+ 0.1°</sup>	16	51.9	95	57.7	65.7	4390	7.2	1.30
1 x 300RM	20.0 <sup>+ 0.3°</sup>	15	52.0	95	57.8	65.8	4500	9.0	1.30
1 x 400RM	22.9 <sup>+ 0.3°</sup>	15	54.9	95	60.7	68.9	4940	12.0	1.37
1 x 500RM	25.7 <sup>+ 0.4°</sup>	15	57.7	95	63.5	71.9	5420	15.0	1.43
1 x 630RM	29.3 <sup>+ 0.5°</sup>	15	62.0	95	67.8	76.3	6120	18.9	1.52
1 x 800RM	33.0 <sup>+ 0.5°</sup>	15	65.7	95	71.5	80.4	6860	24.0	1.60
1 x 1000RM	38.0 <sup>+ 0.5°</sup>	15	70.7	95	76.5	85.6	7770	30.0	1.71
1 x 1200RM	41.0 <sup>+ 0.6°</sup>	15	73.7	95	79.5	88.9	8590	36.0	1.78
1 x 1200RMS	43.6 <sup>+ 0.8°</sup>	15	77.6	95	83.4	93.3	9070	36.0	1.87
1 x 1400RMS	46.6 <sup>+ 1.0°</sup>	15	80.6	95	86.4	96.5	9850	42.0	1.93
1 x 1600RMS	50.0 <sup>+ 1.0°</sup>	15	84.0	95	89.8	100.1	10660	48.0	2.01
1 x 1800RMS	53.3 <sup>+ 1.0°</sup>	15	87.3	95	93.1	103.6	11490	54.0	2.08
1 x 2000RMS	55.4 <sup>+ 1.0°</sup>	15	89.4	95	95.2	105.9	12200	60.0	2.13

\*production range up to 3000 mm<sup>2</sup>; cable data for sections >2000 mm<sup>2</sup> are available on request

# Electrical data

RM (RMC) - Round Multiwire Conductor (C - compacted), Class 2  
 RMS (Milliken type) – Round Multiwire Segmented Conductor  
 SPB - Single Point Bonded  
 CB - Cross Bonded

BE - Both Ends  
 $D_e$  - Cable diameter  
 1 - Cables in flat formation, the distance between cables  $2 \times D_e$   
 2 - Cables in trefoil formation, the distance between cables  $D_e$

Cross section of conductor	Resistance of conductor				Resistance of metallic screen		Electric field strength at the Conductor screen / insulation	Short-circuit current-carrying capacity		Capacitance	Inductance	Current-carrying capacity		
	DC		AC		DC	AC		Conductor	Metallic screen			000 <sup>1</sup>	In ground	In air
	20°C	90°C	20°C	80°C	20°C	80°C						0 <sup>0</sup> 0 <sup>2</sup>	SPB,CB / BE	SPB,CB / BE
mm <sup>2</sup>	Ω/km				kV/mm	kA/1sec.		μF/km	mH/km	A				
1 x 150RM	0.2060	0.2645	0.200	0.247	6.77 / 2.27	14.5	19.0	0.117	0.677	336 / 311		403 / 385		
										0.492		320 / 316		363 / 360
1 x 185RM	0.1640	0.2108	0.200	0.247	6.62 / 2.31	17.8	19.0	0.121	0.659	381 / 346		462 / 437		
										0.474		362 / 356		415 / 410
1 x 240RM	0.1250	0.1609	0.200	0.247	6.66 / 2.55	23.1	19.0	0.133	0.633	442 / 390		546 / 506		
										0.449		420 / 410		487 / 479
1 x 300RM	0.1000	0.1291	0.200	0.247	6.71 / 2.84	28.8	19.0	0.149	0.612	500 / 429		628 / 570		
										0.427		474 / 461		557 / 546
1 x 400RM	0.0778	0.1009	0.200	0.247	6.45 / 2.93	38.3	19.0	0.162	0.594	575 / 474		733 / 649		
										0.409		542 / 523		648 / 631
1 x 500RM	0.0605	0.0791	0.200	0.247	6.25 / 3.00	47.8	19.0	0.174	0.579	659 / 519		852 / 731		
										0.394		618 / 591		750 / 726
1 x 630RM	0.0469	0.0621	0.200	0.247	6.00 / 3.10	60.2	19.0	0.193	0.565	755 / 565		994 / 821		
										0.380		704 / 666		870 / 835
1 x 800RM	0.0367	0.0494	0.200	0.247	5.83 / 3.17	76.4	19.0	0.209	0.552	858 / 607		1148 / 909		
										0.367		795 / 741		999 / 949
1 x 1000RM	0.0291	0.0400	0.200	0.247	5.65 / 3.25	95.3	19.0	0.231	0.536	975 / 691		1323 / 1001		
										0.351		888 / 817		1141 / 1071
1 x 1200RM	0.0247	0.0346	0.200	0.247	5.56 / 3.30	114.3	19.0	0.244	0.528	1049 / 669		1449 / 1059		
										0.344		953 / 867		1240 / 1155
1 x 1200RMS	0.0247	0.0321	0.200	0.247	5.46 / 3.35	114.3	19.0	0.261	0.526	1111 / 688		1546 / 1103		
										0.341		1018 / 915		1335 / 1233
1 x 1400RMS	0.0212	0.0277	0.200	0.247	5.39 / 3.39	133.3	19.0	0.274	0.519	1195 / 716		1696 / 1163		
										0.334		1096 / 972		1456 / 1330
1 x 1600RMS	0.0186	0.0244	0.200	0.247	5.32 / 3.42	152.3	19.0	0.289	0.512	1306 / 788		1848 / 1286		
										0.327		1192 / 1075		1591 / 1473
1 x 1800RMS	0.0165	0.0217	0.200	0.247	5.26 / 3.46	171.2	19.0	0.303	0.506	1380 / 748		1987 / 1267		
										0.321		1237 / 1069		1683 / 1506
1 x 2000RMS	0.0149	0.0197	0.200	0.247	5.23 / 3.48	190.2	19.0	0.313	0.503	1455 / 761		2110 / 1303		
										0.318		1296 / 1107		1777 / 1575

# HIGH-VOLTAGE XLPE CABLES

## 76/132 ÷ 138(145) kV

COPPER CONDUCTOR

N2XS(FL)2Y according to DIN VDE 0276-632

2XS(FL)2Y according to IEC 60840

XRUHKXS according to ZN-TF-530:2009; IEC 60840

80

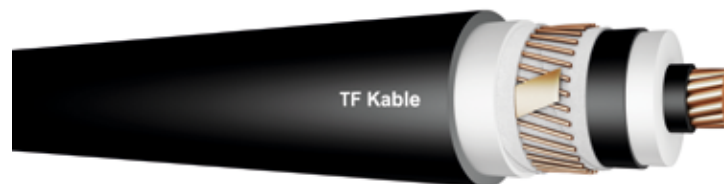

Cross section of conductor*	Diameter of conductor	Insulation		Metallic screen		D <sub>e</sub> Outer diameter of cable	Cable weight	Maximum pulling force	Minimal bending radius
		Nominal thickness	Diameter over insulation	Cross section	Diameter over screen				
mm <sup>2</sup>	mm	mm		mm <sup>2</sup>		mm	kg/km	kN	m
1 x 185RM	16.0 <sup>+0.3°</sup>	17	52.4	95	58.2	66.2	5450	9.3	1.31
1 x 240RM	18.5 <sup>+0.3°</sup>	16	52.5	95	58.3	66.3	5890	12.0	1.31
1 x 300RM	20.5 <sup>+0.3°</sup>	15	52.5	95	58.3	66.3	6370	15.0	1.31
1 x 400RM	23.5 <sup>+0.3°</sup>	15	55.5	95	61.3	69.5	7380	20.0	1.38
1 x 500RM	26.5 <sup>+0.4°</sup>	15	58.5	95	64.3	72.7	8560	25.0	1.45
1 x 630RM	30.3 <sup>+0.4°</sup>	15	63.0	95	68.8	77.5	10160	31.5	1.55
1 x 800RM	34.6 <sup>+0.5°</sup>	15	67.3	95	73.1	82.0	11980	40.0	1.64
1 x 1000RM	38.2 <sup>+0.4°</sup>	15	70.9	95	76.7	85.8	14030	50.0	1.72
1 x 1200RMS	43.6 <sup>+0.8°</sup>	15	77.6	95	83.4	93.3	16520	60.0	1.87
1 x 1400RMS	46.6 <sup>+1.0°</sup>	15	80.6	95	86.4	96.5	18530	70.0	1.93
1 x 1600RMS	50.0 <sup>+1.0°</sup>	15	84.0	95	89.8	100.1	20580	80.0	2.01
1 x 1800RMS	53.3 <sup>+1.0°</sup>	15	87.3	95	93.1	103.6	22630	90.0	2.08
1 x 2000RMS	56.3 <sup>+1.2°</sup>	15	90.3	95	96.1	106.8	24720	100.0	2.15

\*production range up to 3000 mm<sup>2</sup>; cable data for sections >2000 mm<sup>2</sup> are available on request

# Electrical data

RM (RMC) - Round Multiwire Conductor (C - compacted), Class 2  
 RMS (Milliken type) – Round Multiwire Segmented Conductor  
 SPB - Single Point Bonded  
 CB - Cross Bonded

BE - Both Ends  
 $D_e$  - Cable diameter  
 1 - Cables in flat formation, the distance between cables  $2 \times D_e$   
 2 - Cables in trefoil formation, the distance between cables  $D_e$

Cross section of conductor	Resistance of conductor		Resistance of metallic screen		Electric field strength at the Conductor screen / insulation	Short-circuit current-carrying capacity		Capacitance	Inductance	Current-carrying capacity	
	DC 20°C	AC 90°C	DC 20°C	AC 80°C		Conductor	Metallic screen			In ground	In air
mm <sup>2</sup>	Ω/km				kV/mm	kA/1sec.	μF/km	mH/km	A		
1 x 185RM	0.0991	0.1272	0.200	0.247	7.92 / 2.78	26.9	19.0	0.122	0.657	490 / 422	595 / 546
									0.473	465 / 453	534 / 524
1 x 240RM	0.0754	0.0973	0.200	0.247	7.91 / 3.09	34.8	19.0	0.136	0.629	570 / 470	707 / 628
									0.444	539 / 520	629 / 613
1 x 300RM	0.0601	0.0781	0.200	0.247	8.00 / 3.43	43.5	19.0	0.151	0.608	644 / 510	811 / 699
									0.423	607 / 580	717 / 694
1 x 400RM	0.0470	0.0618	0.200	0.247	7.69 / 3.53	57.9	19.0	0.164	0.590	736 / 553	943 / 783
									0.405	690 / 652	828 / 795
1 x 500RM	0.0366	0.0489	0.200	0.247	7.44 / 3.62	72.2	19.0	0.178	0.575	838 / 595	1091 / 869
									0.390	780 / 728	953 / 905
1 x 630RM	0.0283	0.0387	0.200	0.247	7.14 / 3.74	90.9	19.0	0.198	0.561	946 / 641	1264 / 959
									0.377	880 / 808	1095 / 1028
1 x 800RM	0.0221	0.0312	0.200	0.247	6.92 / 3.84	115.4	19.0	0.216	0.546	1074 / 682	1452 / 1046
									0.361	980 / 885	1244 / 1153
1 x 1000RM	0.0176	0.0259	0.200	0.247	6.77 / 3.91	144.1	19.0	0.232	0.535	1185 / 701	1628 / 1118
									0.351	1069 / 951	1380 / 1263
1 x 1200RMS	0.0151	0.0202	0.200	0.247	6.55 / 4.02	172.8	19.0	0.261	0.526	1366 / 738	1910 / 1218
									0.341	1232 / 1062	1625 / 1452
1 x 1400RMS	0.0129	0.0175	0.200	0.247	6.47 / 4.06	201.5	19.0	0.274	0.519	1462 / 763	2085 / 1272
									0.334	1316 / 1116	1759 / 1550
1 x 1600RMS	0.0113	0.0155	0.200	0.247	6.39 / 4.11	230.3	19.0	0.289	0.512	1572 / 772	2250 / 1319
									0.327	1389 / 1162	1882 / 1638
1 x 1800RMS	0.0101	0.0140	0.200	0.247	6.32 / 4.15	259.0	19.0	0.303	0.506	1658 / 785	2400 / 1360
									0.321	1452 / 1200	1990 / 1715
1 x 2000RMS	0.0090	0.0127	0.200	0.247	6.26 / 4.18	287.7	19.0	0.316	0.501	1699 / 812	2552 / 1396
									0.317	1513 / 1235	2097 / 1788

# HIGH-VOLTAGE XLPE CABLES

## 76/132 ÷ 138(145) kV

ALUMINIUM CONDUCTOR

NA2XS(FL)2Y according to DIN VDE 0276-632

A2XS(FL)2Y according to IEC 60840

XRUHAKXS according to ZN-TF-530:2009; IEC 60840

82

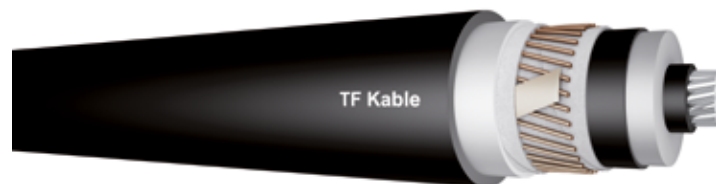

Cross section of conductor*	Diameter of conductor	Insulation		Metallic screen		D <sub>e</sub> Outer diameter of cable	Cable weight	Maximum pulling force	Minimal bending radius
		Nominal thickness	Diameter over insulation	Cross section	Diameter over screen				
mm <sup>2</sup>	mm	mm		mm <sup>2</sup>		mm	kg/km	kN	m
1 x 185RM	15.8 <sup>+0.2°</sup>	17	52.2	95	58.0	66.0	4320	5.6	1.31
1 x 240RM	17.9 <sup>+0.1°</sup>	16	51.9	95	57.7	65.7	4390	7.2	1.30
1 x 300RM	20.0 <sup>+0.3°</sup>	15	52.0	95	57.8	65.8	4500	9.0	1.30
1 x 400RM	22.9 <sup>+0.3°</sup>	15	54.9	95	60.7	68.9	4940	12.0	1.37
1 x 500RM	25.7 <sup>+0.4°</sup>	15	57.7	95	63.5	71.9	5420	15.0	1.43
1 x 630RM	29.3 <sup>+0.5°</sup>	15	62.0	95	67.8	76.3	6120	18.9	1.52
1 x 800RM	33.0 <sup>+0.5°</sup>	15	65.7	95	71.5	80.4	6860	24.0	1.60
1 x 1000RM	38.0 <sup>+0.5°</sup>	15	70.7	95	76.5	85.6	7770	30.0	1.71
1 x 1200RM	41.0 <sup>+0.6°</sup>	15	73.7	95	79.5	88.9	8590	36.0	1.78
1 x 1200RMS	43.6 <sup>+0.8°</sup>	15	77.6	95	83.4	93.3	9070	36.0	1.87
1 x 1400RMS	46.6 <sup>+1.0°</sup>	15	80.6	95	86.4	96.5	9850	42.0	1.93
1 x 1600RMS	50.0 <sup>+1.0°</sup>	15	84.0	95	89.8	100.1	10660	48.0	2.01
1 x 1800RMS	53.3 <sup>+1.0°</sup>	15	87.3	95	93.1	103.6	11490	54.0	2.08
1 x 2000RMS	55.4 <sup>+1.0°</sup>	15	89.4	95	95.2	105.9	12200	60.0	2.13

\*production range up to 3000 mm<sup>2</sup>; cable data for sections >2000 mm<sup>2</sup> are available on request

# Electrical data

RM (RMC) - Round Multiwire Conductor (C - compacted), Class 2  
 RMS (Milliken type) – Round Multiwire Segmented Conductor  
 SPB - Single Point Bonded  
 CB - Cross Bonded

BE - Both Ends  
 $D_e$  - Cable diameter  
 1 - Cables in flat formation, the distance between cables  $2 \times D_e$   
 2 - Cables in trefoil formation, the distance between cables  $D_e$

Cross section of conductor	Resistance of conductor		Resistance of metallic screen		Electric field strength at the Conductor screen / insulation	Short-circuit current-carrying capacity		Capacitance	Inductance	Current-carrying capacity				
	DC 20°C	AC 90°C	DC 20°C	AC 80°C		Conductor	Metallic screen			000 <sup>1</sup>	In ground		In air	
											0 <sup>0</sup> 0 <sup>2</sup>	SPB,CB / BE		SPB,CB / BE
mm <sup>2</sup>	Ω/km				kV/mm	kA/1sec.	μF/km	mH/km	A					
1 x 185RM	0.1640	0.2108	0.200	0.247	7.95 / 2.77	17.8	19.0	0.121	0.659	381 / 346		462 / 437		
										0.474		362 / 356		415 / 410
1 x 240RM	0.1250	0.1609	0.200	0.247	7.99 / 3.06	23.1	19.0	0.133	0.633	442 / 390		546 / 506		
										0.449		420 / 410		487 / 479
1 x 300RM	0.1000	0.1291	0.200	0.247	8.05 / 3.41	28.8	19.0	0.149	0.612	500 / 429		628 / 570		
										0.427		474 / 461		557 / 546
1 x 400RM	0.0778	0.1009	0.200	0.247	7.74 / 3.51	38.3	19.0	0.162	0.594	575 / 474		733 / 649		
										0.409		542 / 523		648 / 631
1 x 500RM	0.0605	0.0791	0.200	0.247	7.50 / 3.60	47.8	19.0	0.174	0.579	659 / 519		852 / 731		
										0.394		618 / 591		750 / 726
1 x 630RM	0.0469	0.0621	0.200	0.247	7.20 / 3.72	60.2	19.0	0.193	0.565	755 / 565		994 / 821		
										0.380		704 / 666		870 / 835
1 x 800RM	0.0367	0.0494	0.200	0.247	7.00 / 3.80	76.4	19.0	0.209	0.552	858 / 607		1148 / 909		
										0.367		795 / 741		999 / 949
1 x 1000RM	0.0291	0.0400	0.200	0.247	6.78 / 3.90	95.3	19.0	0.231	0.536	975 / 691		1323 / 1001		
										0.351		888 / 817		1141 / 1071
1 x 1200RM	0.0247	0.0346	0.200	0.247	6.67 / 3.96	114.3	19.0	0.244	0.528	1049 / 669		1449 / 1059		
										0.344		953 / 867		1240 / 1155
1 x 1200RMS	0.0247	0.0321	0.200	0.247	6.55 / 4.02	114.3	19.0	0.261	0.526	1111 / 688		1546 / 1103		
										0.341		1018 / 915		1335 / 1233
1 x 1400RMS	0.0212	0.0277	0.200	0.247	6.47 / 4.06	133.3	19.0	0.274	0.519	1195 / 716		1696 / 1163		
										0.334		1096 / 972		1456 / 1330
1 x 1600RMS	0.0186	0.0244	0.200	0.247	6.39 / 4.11	152.3	19.0	0.289	0.512	1306 / 788		1848 / 1286		
										0.327		1192 / 1075		1591 / 1473
1 x 1800RMS	0.0165	0.0217	0.200	0.247	6.32 / 4.15	171.2	19.0	0.303	0.506	1380 / 748		1987 / 1267		
										0.321		1237 / 1069		1683 / 1506
1 x 2000RMS	0.0149	0.0197	0.200	0.247	6.28 / 4.17	190.2	19.0	0.313	0.503	1455 / 761		2110 / 1303		
										0.318		1296 / 1107		1777 / 1575

# HIGH-VOLTAGE XLPE CABLES

## 87/150 ÷ 161(170) kV

COPPER CONDUCTOR

N2XS(FL)2Y according to DIN VDE 0276-632

2XS(FL)2Y according to IEC 60840

XRUHKXS according to ZN-TF-530:2009; IEC 60840

84

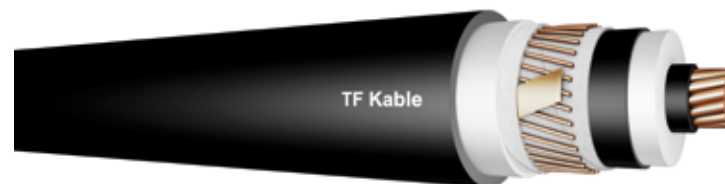

Cross section of conductor*	Diameter of conductor	Insulation		Metallic screen		D <sub>e</sub> Outer diameter of cable	Cable weight	Maximum pulling force	Minimal bending radius
		Nominal thickness	Diameter over insulation	Cross section	Diameter over screen				
mm <sup>2</sup>	mm	mm		mm <sup>2</sup>		mm	kg/km	kN	m
1 x 185RM	16.0 <sup>+0.3°</sup>	23	64.8	95	70.6	79.4	6820	9.3	1.59
1 x 240RM	18.5 <sup>+0.3°</sup>	22	64.5	95	70.3	79.1	7210	12.0	1.58
1 x 300RM	20.5 <sup>+0.3°</sup>	21	64.5	95	70.3	79.1	7690	15.0	1.58
1 x 400RM	23.5 <sup>+0.3°</sup>	20	65.5	95	71.3	80.1	8500	20.0	1.60
1 x 500RM	26.5 <sup>+0.4°</sup>	19	66.5	95	72.3	81.3	9490	25.0	1.62
1 x 630RM	30.3 <sup>+0.4°</sup>	19	71.0	95	76.8	85.9	11130	31.5	1.72
1 x 800RM	34.6 <sup>+0.5°</sup>	19	75.3	95	81.1	90.7	13050	40.0	1.82
1 x 1000RM	38.2 <sup>+0.4°</sup>	19	78.9	95	84.7	94.5	15140	50.0	1.90
1 x 1200RMS	43.6 <sup>+0.8°</sup>	19	85.6	95	91.4	101.9	17720	60.0	2.04
1 x 1400RMS	46.6 <sup>+1.0°</sup>	19	88.6	95	94.4	105.1	19760	70.0	2.11
1 x 1600RMS	50.0 <sup>+1.0°</sup>	19	92.0	95	97.8	108.7	21860	80.0	2.18
1 x 1800RMS	53.3 <sup>+1.0°</sup>	19	95.3	95	101.1	112.2	23950	90.0	2.26
1 x 2000RMS	56.3 <sup>+1.2°</sup>	19	98.3	95	104.1	115.4	26080	100.0	2.32

\*production range up to 3000 mm<sup>2</sup>; cable data for sections >2000 mm<sup>2</sup> are available on request

# Electrical data

RM (RMC) - Round Multiwire Conductor (C - compacted), Class 2  
 RMS (Milliken type) – Round Multiwire Segmented Conductor  
 SPB - Single Point Bonded  
 CB - Cross Bonded

BE - Both Ends  
 $D_e$  - Cable diameter  
 1 - Cables in flat formation, the distance between cables  $2 \times D_e$   
 2 - Cables in trefoil formation, the distance between cables  $D_e$

Cross section of conductor	Resistance of conductor		Resistance of metallic screen		Electric field strength at the conductor screen / insulation	Short-circuit current-carrying capacity		Capacitance	Inductance	Current-carrying capacity	
	DC 20°C	AC 90°C	DC 20°C	AC 80°C		Conductor	Metallic screen			In ground	In air
mm <sup>2</sup>	Ω/km				kV/mm	kA/1sec.		μF/km	mH/km	A	
1 x 185RM	0.0991	0.1271	0.200	0.247	7.45 / 2.16	26.9	19.0	0.103	0.694	488 / 423	582 / 540
									0.509	463 / 452	531 / 522
1 x 240RM	0.0754	0.0972	0.200	0.247	7.37 / 2.34	34.8	19.0	0.111	0.664	567 / 472	690 / 623
									0.479	537 / 519	625 / 611
1 x 300RM	0.0601	0.0780	0.200	0.247	7.31 / 2.55	43.5	19.0	0.121	0.643	641 / 513	791 / 695
									0.459	605 / 580	712 / 692
1 x 400RM	0.0470	0.0617	0.200	0.247	7.20 / 2.80	57.9	19.0	0.135	0.619	733 / 557	922 / 781
									0.434	687 / 652	823 / 794
1 x 500RM	0.0366	0.0488	0.200	0.247	7.17 / 3.07	72.2	19.0	0.151	0.598	835 / 599	1070 / 868
									0.413	779 / 728	947 / 904
1 x 630RM	0.0283	0.0386	0.200	0.247	6.85 / 3.18	90.9	19.0	0.167	0.582	945 / 644	1239 / 961
									0.397	879 / 810	1089 / 1028
1 x 800RM	0.0221	0.0311	0.200	0.247	6.61 / 3.27	115.4	19.0	0.182	0.566	1073 / 676	1422 / 1050
									0.381	980 / 886	1238 / 1153
1 x 1000RM	0.0176	0.0258	0.200	0.247	6.45 / 3.34	144.1	19.0	0.194	0.555	1184 / 705	1594 / 1123
									0.370	1071 / 954	1374 / 1264
1 x 1200RMS	0.0151	0.0202	0.200	0.247	6.20 / 3.45	172.8	19.0	0.218	0.543	1364 / 744	1869 / 1227
									0.358	1230 / 1063	1613 / 1450
1 x 1400RMS	0.0129	0.0175	0.200	0.247	6.11 / 3.49	201.5	19.0	0.228	0.536	1472 / 763	2040 / 1282
									0.351	1316 / 1119	1746 / 1550
1 x 1600RMS	0.0113	0.0155	0.200	0.247	6.02 / 3.53	230.3	19.0	0.240	0.529	1545 / 788	2201 / 1331
									0.344	1389 / 1164	1868 / 1639
1 x 1800RMS	0.0101	0.0140	0.200	0.247	5.94 / 3.57	259.0	19.0	0.251	0.522	1655 / 791	2348 / 1373
									0.337	1452 / 1202	1976 / 1716
1 x 2000RMS	0.0090	0.0127	0.200	0.247	5.88 / 3.61	287.7	19.0	0.261	0.517	1741 / 803	2496 / 1410
									0.332	1516 / 1239	2084 / 1790

# HIGH-VOLTAGE XLPE CABLES

## 87/150 ÷ 161(170) kV

ALUMINIUM CONDUCTOR

NA2XS(FL)2Y according to DIN VDE 0276-632

A2XS(FL)2Y according to IEC 60840

XRUHAKXS according to ZN-TF-530:2009; IEC 60840

86

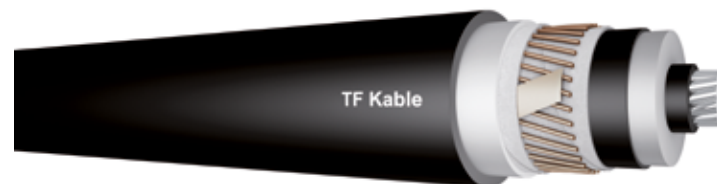

Cross section of conductor*	Diameter of conductor	Insulation		Metallic screen		D <sub>e</sub> Outer diameter of cable	Cable weight	Maximum pulling force	Minimal bending radius
		Nominal thickness	Diameter over insulation	Cross section	Diameter over screen				
mm <sup>2</sup>	mm	mm		mm <sup>2</sup>		mm	kg/km	kN	m
1 x 185RM	15.8 <sup>+0.2°</sup>	23	64.6	95	70.4	79.2	5680	5.6	1.58
1 x 240RM	17.9 <sup>+0.1°</sup>	22	63.9	95	69.7	78.5	5690	7.2	1.57
1 x 300RM	20.0 <sup>+0.3°</sup>	21	64.0	95	69.8	78.6	5810	9.0	1.57
1 x 400RM	22.9 <sup>+0.3°</sup>	20	64.9	95	70.7	79.5	6050	12.0	1.59
1 x 500RM	25.7 <sup>+0.4°</sup>	19	65.7	95	71.5	80.5	6350	15.0	1.61
1 x 630RM	29.3 <sup>+0.5°</sup>	19	70.0	95	75.8	84.9	7100	18.9	1.70
1 x 800RM	33.0 <sup>+0.5°</sup>	19	73.7	95	79.5	88.9	7880	24.0	1.78
1 x 1000RM	38.0 <sup>+0.5°</sup>	19	78.7	95	84.5	94.3	8890	30.0	1.89
1 x 1200RM	41.0 <sup>+0.6°</sup>	19	81.7	95	87.5	97.5	9740	36.0	1.96
1 x 1200RMS	43.6 <sup>+0.8°</sup>	19	85.6	95	91.4	101.9	10260	36.0	2.04
1 x 1400RMS	46.6 <sup>+1.0°</sup>	19	88.6	95	94.4	105.1	11090	42.0	2.11
1 x 1600RMS	50.0 <sup>+1.0°</sup>	19	92.0	95	97.8	108.7	11940	48.0	2.18
1 x 1800RMS	53.3 <sup>+1.0°</sup>	19	95.3	95	101.1	112.2	12810	54.0	2.26
1 x 2000RMS	55.4 <sup>+1.0°</sup>	19	97.4	95	103.2	114.5	13550	60.0	2.30

\*production range up to 3000 mm<sup>2</sup> ; cable data for sections >2000 mm<sup>2</sup> are available on request

# Electrical data

RM (RMC) - Round Multiwire Conductor (C - compacted), Class 2  
 RMS (Milliken type) – Round Multiwire Segmented Conductor  
 SPB - Single Point Bonded  
 CB - Cross Bonded

BE - Both Ends  
 $D_e$  - Cable diameter  
 1 - Cables in flat formation, the distance between cables  $2 \times D_e$   
 2 - Cables in trefoil formation, the distance between cables  $D_e$

Cross section of conductor	Resistance of conductor		Resistance of metallic screen		Electric field strength at the Conductor screen / insulation	Short-circuit current-carrying capacity		Capacitance	Inductance	Current-carrying capacity			
	DC 20°C	AC 90°C	DC 20°C	AC 80°C		Conductor	Metallic screen			ooo <sup>1</sup>	o <sup>0</sup> o <sup>2</sup>	In ground	In air
												SPB,CB / BE	SPB,CB / BE
mm <sup>2</sup>	Ω/km				kV/mm	kA/1sec.	μF/km	mH/km	A				
1 x 185RM	0.1640	0.2107	0.200	0.247	7.48 / 2.15	17.8	19.0	0.103	0.696	379 / 346	451 / 430		
									0.511	361 / 355	412 / 408		
1 x 240RM	0.1250	0.1609	0.200	0.247	7.46 / 2.32	23.1	19.0	0.110	0.669	440 / 391	533 / 499		
									0.484	418 / 409	484 / 477		
1 x 300RM	0.1000	0.1290	0.200	0.247	7.37 / 2.53	28.8	19.0	0.120	0.647	498 / 430	612 / 563		
									0.462	471 / 459	553 / 543		
1 x 400RM	0.0778	0.1009	0.200	0.247	7.26 / 2.79	38.3	19.0	0.133	0.622	572 / 476	717 / 643		
									0.437	540 / 522	643 / 629		
1 x 500RM	0.0605	0.0790	0.200	0.247	7.24 / 3.05	47.8	19.0	0.148	0.602	656 / 521	836 / 727		
									0.417	616 / 590	745 / 723		
1 x 630RM	0.0469	0.0620	0.200	0.247	6.92 / 3.16	60.2	19.0	0.163	0.586	753 / 567	974 / 818		
									0.402	703 / 665	864 / 832		
1 x 800RM	0.0367	0.0493	0.200	0.247	6.69 / 3.24	76.4	19.0	0.176	0.572	856 / 610	1125 / 908		
									0.387	793 / 741	992 / 946		
1 x 1000RM	0.0291	0.0399	0.200	0.247	6.45 / 3.34	95.3	19.0	0.194	0.555	966 / 649	1295 / 1000		
									0.370	888 / 817	1132 / 1068		
1 x 1200RM	0.0247	0.0345	0.200	0.247	6.34 / 3.39	114.3	19.0	0.204	0.547	1046 / 674	1418 / 1060		
									0.362	954 / 869	1232 / 1152		
1 x 1200RMS	0.0247	0.0320	0.200	0.247	6.20 / 3.45	114.3	19.0	0.218	0.543	1108 / 692	1512 / 1105		
									0.358	1015 / 915	1322 / 1227		
1 x 1400RMS	0.0212	0.0276	0.200	0.247	6.11 / 3.49	133.3	19.0	0.228	0.536	1203 / 716	1658 / 1167		
									0.351	1095 / 973	1442 / 1325		
1 x 1600RMS	0.0186	0.0243	0.200	0.247	6.02 / 3.53	152.3	19.0	0.240	0.529	1303 / 790	1806 / 1283		
									0.344	1190 / 1074	1575 / 1464		
1 x 1800RMS	0.0165	0.0217	0.200	0.247	5.94 / 3.57	171.2	19.0	0.251	0.522	1377 / 753	1941 / 1273		
									0.337	1236 / 1070	1668 / 1501		
1 x 2000RMS	0.0149	0.0196	0.200	0.247	5.90 / 3.60	190.2	19.0	0.258	0.519	1452 / 767	2062 / 1311		
									0.334	1295 / 1108	1761 / 1571		

# HIGH-VOLTAGE XLPE CABLES

## 127/220 ÷ 230(245) kV

COPPER CONDUCTOR

2XS(FL)2Y according to IEC 62067

XRUHKXS according to ZN-TF-530:2009; IEC 62067

88

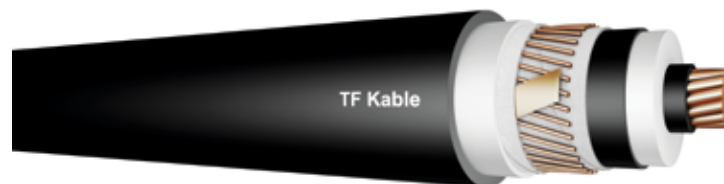

Cross section of conductor*	Diameter of conductor	Insulation		Metallic screen		D <sub>e</sub> Outer diameter of cable	Cable weight	Maximum pulling force	Minimal bending radius
		Nominal thickness	Diameter over insulation	Cross section	Diameter over screen				
mm <sup>2</sup>	mm	mm		mm <sup>2</sup>		mm	kg/km	kN	m
1 x 300RM	20.5 <sup>+0.3°</sup>	24	70.9	95	77.1	86.3	8550	15.0	1.73
1 x 400RM	23.5 <sup>+0.3°</sup>	24	73.9	95	80.1	89.8	9690	20.0	1.79
1 x 500RM	26.5 <sup>+0.4°</sup>	23	74.9	95	81.1	90.8	10680	25.0	1.82
1 x 630RM	30.3 <sup>+0.4°</sup>	22	77.0	95	83.2	93.0	12050	31.5	1.86
1 x 800RM	34.6 <sup>+0.5°</sup>	22	81.3	95	87.5	97.5	13980	40.0	1.96
1 x 1000RM	38.2 <sup>+0.4°</sup>	22	84.9	95	91.1	101.3	16110	50.0	2.04
1 x 1200RMS	43.6 <sup>+0.8°</sup>	22	91.6	95	97.8	108.7	18760	60.0	2.18
1 x 1400RMS	46.6 <sup>+1.0°</sup>	22	94.6	95	100.8	111.9	20840	70.0	2.25
1 x 1600RMS	50.0 <sup>+1.0°</sup>	22	98.0	95	104.2	115.5	22980	80.0	2.32
1 x 1800RMS	53.3 <sup>+1.0°</sup>	22	101.3	95	107.5	119.0	25100	90.0	2.40
1 x 2000RMS	56.3 <sup>+1.2°</sup>	22	104.3	95	110.5	122.2	27270	100.0	2.46
1 x 1600RMS	50.0 <sup>+1.0°</sup>	19	92.0	95	97.8	108.7	11940	48.0	2.18
1 x 1800RMS	53.3 <sup>+1.0°</sup>	19	95.3	95	101.1	112.2	12810	54.0	2.26
1 x 2000RMS	55.4 <sup>+1.0°</sup>	19	97.4	95	103.2	114.5	13550	60.0	2.30

\*production range up to 3000 mm<sup>2</sup> ; cable data for sections >2000 mm<sup>2</sup> are available on request

# Electrical data

RM (RMC) - Round Multiwire Conductor (C - compacted), Class 2  
 RMS (Milliken type) – Round Multiwire Segmented Conductor  
 SPB - Single Point Bonded  
 CB - Cross Bonded

BE - Both Ends  
 $D_e$  - Cable diameter  
 1 - Cables in flat formation, the distance between cables  $2 \times D_e$   
 2 - Cables in trefoil formation, the distance between cables  $D_e$

Cross section of conductor	Resistance of conductor		Resistance of metallic screen		Electric field strength at the Conductor screen / insulation	Short-circuit current-carrying capacity		Capacitance	Inductance	Current-carrying capacity	
	DC 20°C	AC 90°C	DC 20°C	AC 80°C		Conductor	Metallic screen			In ground	In air
mm <sup>2</sup>	Ω/km				kV/mm	kA/1sec.		μF/km	mH/km	A	
1 x 300RM	0.0601	0.0779	0.200	0.247	9.82 / 3.17	43.5	19.0	0.113	0.661	635 / 510	777 / 689
									0.476	598 / 574	704 / 686
1 x 400RM	0.0470	0.0616	0.200	0.247	9.35 / 3.28	57.9	19.0	0.122	0.642	725 / 554	901 / 774
									0.457	680 / 645	813 / 786
1 x 500RM	0.0366	0.0487	0.200	0.247	9.23 / 3.56	72.2	19.0	0.134	0.620	826 / 596	1045 / 863
									0.435	769 / 720	935 / 895
1 x 630RM	0.0283	0.0385	0.200	0.247	9.09 / 3.89	90.9	19.0	0.151	0.598	941 / 635	1215 / 951
									0.413	870 / 798	1077 / 1016
1 x 800RM	0.0221	0.0311	0.200	0.247	8.74 / 4.01	115.4	19.0	0.164	0.581	1059 / 673	1394 / 1047
									0.396	968 / 877	1224 / 1144
1 x 1000RM	0.0176	0.0258	0.200	0.247	8.51 / 4.10	144.1	19.0	0.175	0.569	1169 / 702	1563 / 1121
									0.384	1058 / 944	1358 / 1255
1 x 1200RMS	0.0151	0.0201	0.200	0.247	8.15 / 4.24	172.8	19.0	0.195	0.556	1345 / 739	1830 / 1227
									0.371	1212 / 1049	1591 / 1438
1 x 1400RMS	0.0129	0.0174	0.200	0.247	8.02 / 4.29	201.5	19.0	0.204	0.549	1452 / 738	1998 / 1282
									0.364	1296 / 1104	1723 / 1537
1 x 1600RMS	0.0113	0.0154	0.200	0.247	7.89 / 4.35	230.3	19.0	0.214	0.541	1548 / 773	2155 / 1332
									0.356	1369 / 1150	1844 / 1627
1 x 1800RMS	0.0101	0.0140	0.200	0.247	7.78 / 4.40	259.0	19.0	0.224	0.534	1612 / 792	2298 / 1374
									0.349	1430 / 1186	1951 / 1704
1 x 2000RMS	0.0090	0.0126	0.200	0.247	7.69 / 4.45	287.7	19.0	0.233	0.528	1717 / 797	2443 / 1414
									0.344	1492 / 1222	2057 / 1778

# HIGH-VOLTAGE XLPE CABLES

## 127/220 ÷ 230(245) kV

ALUMINIUM CONDUCTOR

A2XS(FL)2Y according to IEC 62067

XRUHAKXS according to ZN-TF-530:2009; IEC 62067

90

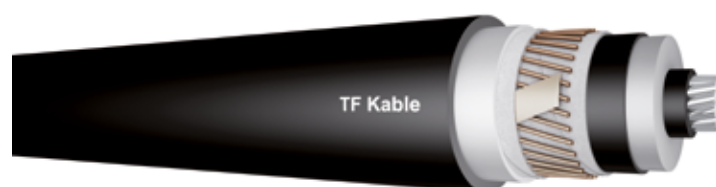

Cross section of conductor*	Diameter of conductor	Insulation		Metallic screen		D <sub>e</sub> Outer diameter of cable	Cable weight	Maximum pulling force	Minimal bending radius
		Nominal thickness	Diameter over insulation	Cross section	Diameter over screen				
mm <sup>2</sup>	mm	mm		mm <sup>2</sup>		mm	kg/km	kN	m
1 x 300RM	20.0 <sup>+0.3°</sup>	24	70.4	95	76.6	85.8	6660	9.0	1.72
1 x 400RM	22.9 <sup>+0.3°</sup>	24	73.3	95	79.5	89.0	7200	12.0	1.78
1 x 500RM	25.7 <sup>+0.4°</sup>	23	74.1	95	80.3	90.0	7530	15.0	1.80
1 x 630RM	29.3 <sup>+0.5°</sup>	22	76.0	95	82.2	91.8	7990	18.9	1.84
1 x 800RM	33.0 <sup>+0.5°</sup>	22	79.7	95	85.9	95.9	8820	24.0	1.92
1 x 1000RM	38.0 <sup>+0.5°</sup>	22	84.7	95	90.9	101.1	9860	30.0	2.03
1 x 1200RM	41.0 <sup>+0.6°</sup>	22	87.7	95	93.9	104.3	10740	36.0	2.10
1 x 1200RMS	43.6 <sup>+0.8°</sup>	22	91.6	95	97.8	108.7	11310	36.0	2.18
1 x 1400RMS	46.6 <sup>+1.0°</sup>	22	94.6	95	100.8	111.9	12170	42.0	2.25
1 x 1600RMS	50.0 <sup>+1.0°</sup>	22	98.0	95	104.2	115.5	13050	48.0	2.32
1 x 1800RMS	53.3 <sup>+1.0°</sup>	22	101.3	95	107.5	119.0	13970	54.0	2.40
1 x 2000RMS	55.4 <sup>+1.0°</sup>	22	103.4	95	109.6	121.3	14720	60.0	2.44
1 x 2000RMS	56.3 <sup>+1.2°</sup>	19	98.3	95	104.1	115.4	26080	100.0	2.32

\*production range up to 3000 mm<sup>2</sup> ; cable data for sections >2000 mm<sup>2</sup> are available on request

# Electrical data

RM (RMC) - Round Multiwire Conductor (C - compacted), Class 2  
 RMS (Milliken type) – Round Multiwire Segmented Conductor  
 SPB - Single Point Bonded  
 CB - Cross Bonded

BE - Both Ends  
 $D_e$  - Cable diameter  
 1 - Cables in flat formation, the distance between cables  $2 \times D_e$   
 2 - Cables in trefoil formation, the distance between cables  $D_e$

Cross section of conductor	Resistance of conductor		Resistance of metallic screen		Electric field strength at the Conductor screen / insulation	Short-circuit current-carrying capacity		Capacitance	Inductance	Current-carrying capacity				
	DC 20°C	AC 90°C	DC 20°C	AC 80°C		Conductor	Metallic screen			ooo <sup>1</sup>	In ground		In air	
											o <sup>0</sup> o <sup>2</sup>	SPB,CB / BE		SPB,CB / BE
mm <sup>2</sup>	Ω/km				kV/mm	kA/1sec.	μF/km	mH/km	A					
1 x 300RM	0.1000	0.1290	0.200	0.247	9.90 / 3.15	28.8	19.0	0.112	0.665	493 / 427	601 / 557			
									0.480	466 / 454	547 / 538			
1 x 400RM	0.0778	0.1008	0.200	0.247	9.44 / 3.26	38.3	19.0	0.120	0.645	566 / 472	701 / 635			
									0.460	534 / 516	635 / 622			
1 x 500RM	0.0605	0.0789	0.200	0.247	9.32 / 3.54	47.8	19.0	0.132	0.624	649 / 517	816 / 718			
									0.439	609 / 583	735 / 715			
1 x 630RM	0.0469	0.0619	0.200	0.247	9.18 / 3.86	60.2	19.0	0.148	0.602	744 / 563	955 / 810			
									0.417	694 / 657	854 / 823			
1 x 800RM	0.0367	0.0492	0.200	0.247	8.86 / 3.97	76.4	19.0	0.159	0.587	846 / 605	1102 / 899			
									0.402	784 / 732	980 / 935			
1 x 1000RM	0.0291	0.0398	0.200	0.247	8.52 / 4.09	95.3	19.0	0.174	0.569	954 / 644	1269 / 992			
									0.384	877 / 807	1118 / 1056			
1 x 1200RM	0.0247	0.0344	0.200	0.247	8.35 / 4.16	114.3	19.0	0.183	0.560	1032 / 669	1389 / 1052			
									0.375	941 / 857	1216 / 1140			
1 x 1200RMS	0.0247	0.0320	0.200	0.247	8.15 / 4.24	114.3	19.0	0.195	0.556	1093 / 687	1480 / 1098			
									0.371	1000 / 901	1303 / 1213			
1 x 1400RMS	0.0212	0.0276	0.200	0.247	8.02 / 4.29	133.3	19.0	0.204	0.549	1186 / 710	1623 / 1159			
									0.364	1078 / 958	1421 / 1309			
1 x 1600RMS	0.0186	0.0243	0.200	0.247	7.89 / 4.35	152.3	19.0	0.214	0.541	1285 / 779	1767 / 1269			
									0.356	1172 / 1057	1551 / 1444			
1 x 1800RMS	0.0165	0.0216	0.200	0.247	7.78 / 4.40	171.2	19.0	0.224	0.534	1357 / 747	1899 / 1266			
									0.349	1216 / 1053	1643 / 1484			
1 x 2000RMS	0.0149	0.0196	0.200	0.247	7.72 / 4.43	190.2	19.0	0.231	0.530	1431 / 760	2016 / 1304			
									0.345	1275 / 1091	1736 / 1553			

# HIGH-VOLTAGE XLPE CABLES

## 220/380 ÷ 400(420) kV

COPPER CONDUCTOR

2XS(FL)2Y according to IEC 62067

XRUHKXS according to ZN-TF-530:2009; IEC 62067

92

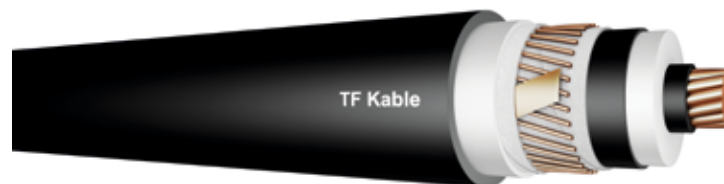

Cross section of conductor*	Diameter of conductor	Insulation		Metallic screen		D <sub>e</sub> Outer diameter of cable	Cable weight	Maximum pulling force	Minimal bending radius
		Nominal thickness	Diameter over insulation	Cross section	Diameter over screen				
mm <sup>2</sup>	mm	mm		mm <sup>2</sup>		mm	kg/km	kN	m
1 x 630RM	30.3 + <sup>0.40</sup>	31.0	96.6	95	103.0	114.6	15300	31.5	2.86
1 x 800RM	34.6 + <sup>0.50</sup>	31.0	100.9	95	107.5	119.1	17370	40.0	2.96
1 x 1000RM	38.2 + <sup>0.40</sup>	30.0	101.5	95	108.0	119.7	19050	50.0	3.00
1 x 1200RMS	43.6 + <sup>0.80</sup>	29.0	105.4	95	112.0	124.0	21330	60.0	3.10
1 x 1400RMS	46.6 + <sup>1.00</sup>	27.0	105.0	95	111.6	123.6	22810	70.0	3.09
1 x 1600RMS	50.0 + <sup>1.00</sup>	27.0	108.0	95	114.5	126.8	25030	80.0	3.17
1 x 1800RMS	53.3 + <sup>1.00</sup>	27.0	111.3	95	117.8	130.3	27150	90.0	3.25
1 x 2000RMS	56.3 + <sup>1.0</sup>	26.0	112.3	95	118.8	131.3	28970	100.0	3.28
1 x 2500RMS	62.4 + <sup>1.0</sup>	26.0	121.0	150	128.0	141.0	36080	100.0	3.52
1 x 3000RMS	68.0 + <sup>1.0</sup>	26.0	125.0	150	132.0	145.4	41220	100.0	3.60

# Electrical data

RM (RMC) - Round Multiwire Conductor (C - compacted), Class 2  
 RMS (Milliken type) – Round Multiwire Segmented Conductor  
 SPB - Single Point Bonded  
 CB - Cross Bonded

BE - Both Ends  
 $D_e$  - Cable diameter  
 1 - Cables in flat formation, the distance between cables  $2 \times D_e$   
 2 - Cables in trefoil formation, the distance between cables  $D_e$

Cross section of conductor	Resistance of conductor		Resistance of metallic screen		Electric field strength at the Conductor screen / insulation	Short-circuit current-carrying capacity		Capacitance	Inductance	Current-carrying capacity	
	DC 20°C	AC 90°C	DC 20°C	AC 80°C		Conductor	Metallic screen			In ground	In air
mm <sup>2</sup>	Ω/km				kV/mm	kA/1sec.		μF/km	mH/km	A	
1 x 630RM	0.0283	0.0385	0.200	0.247	12.40/4.45	90.9	19.0	0.130	0.640	930/660	1165/950
									0.460	865/780	1060/1000
1 x 800RM	0.0221	0.0311	0.200	0.247	11.90/4.60	115.4	19.0	0.140	0.620	1050/695	1340/1045
									0.440	970/860	1210/1120
1 x 1000RM	0.0176	0.0258	0.200	0.247	11.85/4.85	144.1	19.0	0.150	0.605	1160/725	1350/1235
									0.420	1070/925	1350/1235
1 x 1200RMS	0.0151	0.0201	0.200	0.247	11.65/5.30	172.8	19.0	0.170	0.585	1335/765	1775/1230
									0.400	1235/1010	1595/1400
1 x 1400RMS	0.0129	0.0174	0.200	0.247	11.95/5.80	201.5	19.0	0.185	0.570	1445/780	1950/1285
									0.385	1325/1055	1735/1495
1 x 1600RMS	0.0113	0.0154	0.200	0.247	11.80/5.90	230.3	19.0	0.190	0.560	1540/795	2110/1335
									0.375	1405/1095	1865/1580
1 x 1800RMS	0.0101	0.0140	0.200	0.247	11.60/5.95	259.0	19.0	0.200	0.555	1630/805	2250/1380
									0.370	1475/1130	1980/1655
1 x 2000RMS	0.0090	0.0126	0.200	0.247	11.75/6.30	287.7	19.0	0.215	0.545	1700/815	2355/1405
									0.360	1535/1155	2065/1705
1 x 2500RMS	0.0072	0.0106	0.135	0.150	11.35/6.50	359.8	29.1	0.240	0.540	1885/830	2675/1480
									0.355	1675/1150	2315/1780
1 x 3000RMS	0.0062	0.0095	0.135	0.150	11.25/6.55	430.8	29.1	0.250	0.530	2045/845	2950/1530
									0.345	1790/1185	2525/1880

# HIGH-VOLTAGE XLPE CABLES

## 220/380 ÷ 400(420) kV

ALUMINIUM CONDUCTOR

A2XS(FL)2Y according to IEC 62067

XRUHAKXS according to ZN-TF-530:2009; IEC 62067

94

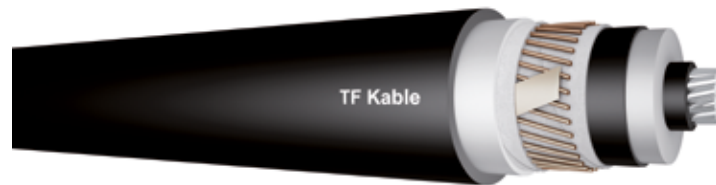

Cross section of conductor*	Diameter of conductor	Insulation		Metallic screen		D <sub>e</sub> Outer diameter of cable	Cable weight	Maximum pulling force	Minimal bending radius
		Nominal thickness	Diameter over insulation	Cross section	Diameter over screen				
mm <sup>2</sup>	mm	mm		mm <sup>2</sup>		mm	kg/km	kN	m
1 x 630RM	29.3 + <sup>0.50</sup>	31.0	95.6	95	102.0	113.4	11190	18.9	2.80
1 x 800RM	33.0 + <sup>0.50</sup>	31.0	99.3	95	105.8	117.5	12150	24.0	2.90
1 x 1000RM	38.0 + <sup>0.50</sup>	30.0	101.3	95	107.8	119.5	12780	30.0	2.95
1 x 1200RMS	41.0 + <sup>0.60</sup>	29.0	103.8	95	110.2	122.2	13580	36.0	3.00
1 x 1200RMS	43.6 + <sup>0.80</sup>	29.0	105.4	95	112.0	124.0	13840	36.0	3.10
1 x 1400RMS	46.6 + <sup>1.00</sup>	27.0	104.4	95	110.8	122.8	13990	42.0	3.05
1 x 1600RMS	50.0 + <sup>1.00</sup>	27.0	108.0	95	114.5	126.8	15030	48.0	3.15
1 x 1800RMS	53.3 + <sup>1.00</sup>	27.0	111.3	95	117.8	130.3	16020	54.0	3.25
1 x 2000RMS	55.4 + <sup>1.00</sup>	26.0	111.4	95	117.9	130.4	16380	60.0	3.25
1 x 2500RMS	61.4 + <sup>1.00</sup>	26.0	120.0	150	126.8	140.0	19520	60.0	3.50
1 x 3000RMS	67.0 + <sup>1.00</sup>	26.0	125.6	150	132.4	146.0	21700	60.0	3.65

# Electrical data

RM (RMC) - Round Multiwire Conductor (C - compacted), Class 2  
 RMS (Milliken type) – Round Multiwire Segmented Conductor  
 SPB - Single Point Bonded  
 CB - Cross Bonded

BE - Both Ends  
 $D_e$  - Cable diameter  
 1 - Cables in flat formation, the distance between cables  $2 \times D_e$   
 2 - Cables in trefoil formation, the distance between cables  $D_e$

Cross section of conductor	Resistance of conductor		Resistance of metallic screen		Electric field strength at the Conductor screen / insulation	Short-circuit current-carrying capacity		Capacitance	Inductance	Current-carrying capacity	
	DC 20°C	AC 90°C	DC 20°C	AC 80°C		Conductor	Metallic screen			In ground	In air
mm <sup>2</sup>	Ω/km				kV/mm	kA/1sec.		μF/km	mH/km	A	
1 x 630RM	0.0469	0.0619	0.200	0.247	12.55/4.40	60.2	19.0	0.130	0.645	730/580	915/800
									0.460	690/645	835/805
1 x 800RM	0.0367	0.0492	0.200	0.247	12.10/4.55	76.4	19.0	0.135	0.630	835/625	1055/890
									0.445	780/720	965/915
1 x 1000RM	0.0291	0.0398	0.200	0.247	11.90/4.85	95.3	19.0	0.150	0.605	945/665	1225/990
									0.420	875/790	1105/1035
1 x 1200RM	0.0247	0.0344	0.200	0.247	11.75/5.20	114.3	19.0	0.165	0.585	1025/695	1355/1060
									0.400	945/840	1215/1130
1 x 1200RMS	0.0247	0.0320	0.200	0.247	11.65/5.30	114.3	19.0	0.170	0.585	1070/705	1415/1085
									0.400	990/875	1275/1180
1 x 1400RMS	0.0212	0.0276	0.200	0.247	12.00/5.80	133.3	19.0	0.185	0.575	1160/730	1565/1155
									0.390	1070/925	1405/1280
1 x 1600RMS	0.0186	0.243	0.200	0.247	11.80/5.90	152.3	19.0	0.195	0.560	1250/750	1700/1210
									0.380	1150/975	1520/1365
1 x 1800RMS	0.0165	0.0216	0.200	0.247	11.60/5.95	171.2	19.0	0.200	0.555	1335/770	1835/1265
									0.370	1220/1020	1630/1450
1 x 2000RMS	0.0149	0.0196	0.200	0.247	11.80/6.30	190.2	19.0	0.215	0.545	1405/780	1955/1305
									0.365	1280/1050	1730/1520
1 x 2500RMS	0.0120	0.0158	0.135	0.150	11.40/6.50	237.5	29.1	0.235	0.540	1530/790	2160/1365
									0.355	1385/1060	1900/1585
1 x 3000RMS	0.0062	0.0100	0.135	0.150	11.20/6.55	284.9	29.1	0.250	0.530	1760/820	2520/1460
									0.345	1570/1135	2195/1755

# HIGH-VOLTAGE XLPE CABLES

## 220/380 ÷ 400(420) kV

ALUMINIUM CONDUCTOR

A2XS(FL)2Y according to IEC 62067

XRUHAKXS according to ZN-TF-530:2009; IEC 62067

96

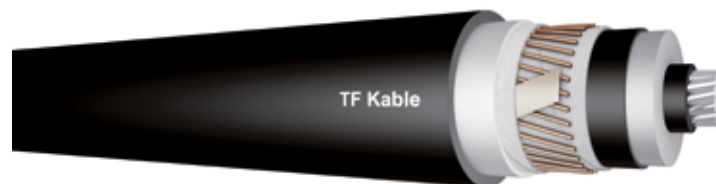

Cross section of conductor*	Diameter of conductor	Insulation		Metallic screen		D <sub>e</sub> Outer diameter of cable	Cable weight	Maximum pulling force	Minimal bending radius
		Nominal thickness	Diameter over insulation	Cross section	Diameter over screen				
mm <sup>2</sup>	mm	mm		mm <sup>2</sup>		mm	kg/km	kN	m
1 x 630RM	29.3 + <sup>0.50</sup>	31.0	95.6	95	102.0	113.4	11190	18.9	2.80
1 x 800RM	33.0 + <sup>0.50</sup>	31.0	99.3	95	105.8	117.5	12150	24.0	2.90
1 x 1000RM	38.0 + <sup>0.50</sup>	30.0	101.3	95	107.8	119.5	12780	30.0	2.95
1 x 1200RMS	41.0 + <sup>0.60</sup>	29.0	103.8	95	110.2	122.2	13580	36.0	3.00
1 x 1200RMS	43.6 + <sup>0.80</sup>	29.0	105.4	95	112.0	124.0	13840	36.0	3.10
1 x 1400RMS	46.6 + <sup>1.00</sup>	27.0	104.4	95	110.8	122.8	13990	42.0	3.05
1 x 1600RMS	50.0 + <sup>1.00</sup>	27.0	108.0	95	114.5	126.8	15030	48.0	3.15
1 x 1800RMS	53.3 + <sup>1.00</sup>	27.0	111.3	95	117.8	130.3	16020	54.0	3.25
1 x 2000RMS	55.4 + <sup>1.00</sup>	26.0	111.4	95	117.9	130.4	16380	60.0	3.25
1 x 2500RMS	61.4 + <sup>1.00</sup>	26.0	120.0	150	126.8	140.0	19520	60.0	3.50
1 x 3000RMS	67.0 + <sup>1.00</sup>	26.0	125.6	150	132.4	146.0	21700	60.0	3.65

# Electrical data

RM (RMC) - Round Multiwire Conductor (C - compacted), Class 2  
 RMS (Milliken type) – Round Multiwire Segmented Conductor  
 SPB - Single Point Bonded  
 CB - Cross Bonded

BE - Both Ends  
 $D_e$  - Cable diameter  
 1 - Cables in flat formation, the distance between cables  $2 \times D_e$   
 2 - Cables in trefoil formation, the distance between cables  $D_e$

Cross section of conductor	Resistance of conductor		Resistance of metallic screen		Electric field strength at the Conductor screen / insulation	Short-circuit current-carrying capacity		Capacitance	Inductance	Current-carrying capacity	
	DC 20°C	AC 90°C	DC 20°C	AC 80°C		Conductor	Metallic screen			0 <sup>0</sup> 0 <sup>2</sup>	In ground
mm <sup>2</sup>	Ω/km				kV/mm	kA/1sec.		μF/km	mH/km	A	
1 x 630RM	0.0469	0.0619	0.200	0.247	12.55/4.40	60.2	19.0	0.130	0.645	730/580	915/800
									0.460	690/645	835/805
1 x 800RM	0.0367	0.0492	0.200	0.247	12.10/4.55	76.4	19.0	0.135	0.630	835/625	1055/890
									0.445	780/720	965/915
1 x 1000RM	0.0291	0.0398	0.200	0.247	11.90/4.85	95.3	19.0	0.150	0.605	945/665	1225/990
									0.420	875/790	1105/1035
1 x 1200RM	0.0247	0.0344	0.200	0.247	11.75/5.20	114.3	19.0	0.165	0.585	1025/695	1355/1060
									0.400	945/840	1215/1130
1 x 1200RMS	0.0247	0.0320	0.200	0.247	11.65/5.30	114.3	19.0	0.170	0.585	1070/705	1415/1085
									0.400	990/875	1275/1180
1 x 1400RMS	0.0212	0.0276	0.200	0.247	12.00/5.80	133.3	19.0	0.185	0.575	1160/730	1565/1155
									0.390	1070/925	1405/1280
1 x 1600RMS	0.0186	0.243	0.200	0.247	11.80/5.90	152.3	19.0	0.195	0.560	1250/750	1700/1210
									0.380	1150/975	1520/1365
1 x 1800RMS	0.0165	0.0216	0.200	0.247	11.60/5.95	171.2	19.0	0.200	0.555	1335/770	1835/1265
									0.370	1220/1020	1630/1450
1 x 2000RMS	0.0149	0.0196	0.200	0.247	11.80/6.30	190.2	19.0	0.215	0.545	1405/780	1955/1305
									0.365	1280/1050	1730/1520
1 x 2500RMS	0.0120	0.0158	0.135	0.150	11.40/6.50	237.5	29.1	0.235	0.540	1530/790	2160/1365
									0.355	1385/1060	1900/1585
1 x 3000RMS	0.0062	0.0100	0.135	0.150	11.20/6.55	284.9	29.1	0.250	0.530	1760/820	2520/1460
									0.345	1570/1135	2195/1755

# Rubber Cables For Wind Farms



# Table of Contents

H07ZZ-F WIND	100
DLO TORSIONFLEX RHH/RHW-2 2000 V, RW90/RW90-TC 1000 V	103
NSHXAFÖ	105



# H07ZZ-F WIND

## 450/750 V

**Standards: PN-EN 50525-3-21**

Flexible cables, cross-linked halogen-free compound insulated and sheathed, with low smoke and corrosive gases emission

100

## CONSTRUCTION

Conductors	Annealed flexible special stranded bare copper conductor class 5 to EN 60228
Separator	A suitable tape separator between the conductor and insulation
Insulation	Cross-linked halogen free thermosetting compound type EI8 in acc. to EN 50363-5
Circuit identification	Colour coding of power conductors comply to HD 308, DIN VDE 0293-308
Colour of insulation	white
Outer jacket	Cross-linked halogen free thermosetting compound type EM8 in acc. to EN 50363-6
Colour of outer jacket	Black or colours can be provided
Flame propagation	IEC 60332-1-2:2004 ,EN 60332-1-2:2004
Torsion resistance	92 °/m



## CHARACTERISTICS

Application	For use in wind turbines. Also, for indoor and temporary outdoors usage, particularly in the case of fire/burning when low emission of smoke and corrosive gases is required
Temperature range	Maximum conductor operating temperature: +90°C Maximum conductor temperature during short circuit: +250°C Maximum cable surface: +80°C Minimum installation and handling: -5°C
Low smoke, halogen free, flame retardant jacket	
UV, sunlight, ozone and oil resistant	
Ink jet printed for easy identification	
Standard length cable packing	1000m on drums. Other forms of packing and delivery are available on request

Number and cross-sectional area of conductor	Maximum diameter of wires	Nominal thickness of insulation	Nominal thickness of sheath	Approximate overall diameter	Approximate net weight	Maximum conductor resistance at temperature 20°C
<b>n x mm<sup>2</sup></b>	<b>mm</b>	<b>mm</b>	<b>mm</b>	<b>mm</b>	<b>kg/km</b>	<b>Ω/km</b>
1x1.5	0.26	0.8	1.4	5.9	49	13.7
1x2.5	0.26	0.9	1.4	6.6	65	8.21
1x4	0.31	1.0	1.5	7.5	88	5.09
1x6	0.31	1.0	1.6	8.2	114	3.39
1x10	0.41	1.2	1.8	10.1	178	1.95
1x16	0.41	1.2	1.9	11.4	247	1.24
1x25	0.41	1.4	2.0	13.2	353	0.795
1x35	0.41	1.4	2.2	14.4	462	0.565
1x50	0.41	1.6	2.4	17.1	648	0.393
1x70	0.51	1.6	2.6	19.3	870	0.277
1x95	0.51	1.8	2.8	22.2	1135	0.210
1x120	0.51	1.8	3.0	23.7	1426	0.164
1x150	0.51	2.0	3.2	26.3	1726	0.132
1x185	0.51	2.2	3.4	29.4	2098	0.108
1x240	0.51	2.4	3.5	31.5	2652	0.0817
1x300	0.51	2.6	3.6	35.7	3290	0.0654
1x400	0.51	2.8	3.8	38.4	4199	0.0495
1x500	0.61	3.0	4.0	43.8	5353	0.0391
1x630	0.61	3.0	4.1	48.4	6829	0.0391

\* Based on standard

## Current ratings for cables for ambient temperature 30°C

Installations	In open air *	Multicore cable for the application for household equipment		Multicore cable (for application other than household equipment) <sup>1 2</sup>
		2	3	
Number of loaded cores	1	2	3	2 or 3
<b>mm<sup>2</sup></b>	<b>A</b>			
1	19	10	10	15
1.5	24	16	16	18
2.5	32	25	20	26
4	42	32	25	34
6	54	40	-	44
10	73	63	-	61
16	98	-	-	82
25	129	-	-	108
35	158	-	-	135
50	198	-	-	168
70	245	-	-	207

Installations	In open air *	Multicore cable for the application for household equipment		Multicore cable (for application other than household equipment) <sup>1,2</sup>
		2	3	
Number of loaded cores	1	2	3	2 or 3
<b>mm<sup>2</sup></b>	<b>A</b>			
95	292	-	-	250
120	344	-	-	292
150	391	-	-	335
185	448	-	-	382
240	528	-	-	453
300	608	-	-	523
400	726	-	-	-
500	830	-	-	-

\* Current rating acc. to HD 516 S2 and DIN VDE 0298-4. Ambient temperature: 30°C. Permissible operating temperature at conductor: 70°C

## Conversion factors for ambient temperature over 30°C

Ambient temperature, °C	30	35	40	45	50	55	60	65
Conversion factors	1.00	0.94	0.87	0.79	0.71	0.61	0.50	0.35

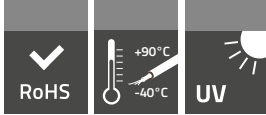

# DLO TORSIONFLEX

## RHH/RHW-2 2000 V

## RW90/RW90-TC 1000 V

**Standards: UL 44, UL 1685, IEEE-1202, CSA c22.2 No. 38 CSA C22.2 No. 230  
ASTM B-3, Based on GE Specification 104W7006**

Portable Power Cables 90 oC UL C(UL)  
Industrial Grade

### CONSTRUCTION

Nominal voltage	RHH/RHW-2 600 and 2000V, RW90 CSA 1kV
Conductors	Annealed flexible stranded bare copper ASTM B-3
Separator	White polyester tape applied longitudinally between conductor and insulation
Insulation	Ethylene-propylene rubber (HEPR), UL, CSA, ICEA, 90 oC.; min. 1000psi
Color of insulation	Black
Jacket	Heavy duty CPE thermosetting compound with improved mechanical properties, ICEA S-95-658 NEMA WC-70; min. 1400psi
Color of jacket	Black
Bending radius	Minimum 8xD
Torsion resistant	92°/m



### CHARACTERISTICS

UL listed RHH/RHW-2 600V and 2000V for black jacket	
RW90 1kV	
90°C (dry), 90°C (wet)	
Ozone, sunlight, oil, grease, weather, chemical and abrasion resistant	
Rated RW90-TC (Tray Cable) for sizes 1/0 and larger	
MSHA, VW-1, SUN RES, FOR CT USE for sizes 1/0AWG and larger and for black jacket	
Limited Smoke (LS) ST1 in accordance with (UL) 1685	
CSA listed RW90, RW90-TC (for black jacket ) 1kV	
Application	For wind turbine as power, control Tray cables. Designed for uses requiring a flexible power cables. For portable or fixed installations. Leads for motors generators, batteries, jumper cables. Deep well Submersible Pump Cable. Other industrial applications
Standard length cable packing	1000ft on drums. Other forms of packing and delivery are available on request

# APPROVALS

UL : E193954(CPE jacket) RHW-2 90 oC wet and dry, VW-1 Sun Res, for 1/0 and larger ST1, FT4 IEEE 120, for CT use  
 C(UL) E193954 Type RW90 EP, 1kV FT1  
 CSA 1101269, LL 103932:205591, RW90 OC FT1, FT4, -40 OC, for 1/0AWG and larger, Oil Res, Tray Cable, Sun Res

Power Conductor Size	Power Conductor Stranding		Conductor Diameter		Nominal insulation thickness		Nominal jacket thickness		Overall diameter min/nom/max		Weight		Ampac. at 30°C in air
	AWG or MCM	N x mm	N x inches	Inch	mm	Inch	mm	Inch	mm	Inches	mm	LBS/1000ft	
14	19x0.373	19x0.0147	0.07	1.83	0.045	1.14	0.015	0.38	0.182/ 0.194/ 0.206	4.63/ 4.93/ 5.23	28	41	35
10	19x0.594	19x0.0234	0.11	2.9	0.045	1.14	0.030	0.76	0.257/ 0.269/ 0.281	6.53/ 6.83/ 7.13	60	90	55
6	65x0.511	65x0.0201	0.19	4.72	0.060	1.52	0.030	0.76	0.351/ 0.37/ 0.389	8.91/ 9.39/ 9.87	126	188	105
4	105x0.511	105x0.0201	0.240	6.1	0.060	1.52	0.030	0.76	0.420/ 0.435/ 0.465	10.67/ 11.05/ 11.81	192	286	140
1	224x0.511	224x0.0201	0.366	9.3	0.080	2.03	0.045	1.14	0.653/ 0.668/ 0.684	16.58/ 16.97/ 17.38	421	628	220
1/0	273x0.511	273x0.0201	0.417	10.6	0.080	2.03	0.045	1.14	0.656/ 0.671/ 0.725	16.65/ 17.05/ 18.41	466	693	260
4/0	532x0.511	224x0.0201	0.590	14.9	0.080	2.03	0.065	1.65	0.827/ 0.870/ 0.914	21.0/ 22.10/ 23.21	872	1299	405
262	646x0.511	646x0.0201	0.638	16.2	0.090	2.28	0.065	1.65	0.950/ 0.966/ 0.982	24.14/ 24.53/ 24.95	1056	1574	471
373	925x0.511	925x0.0201	0.772	19.6	0.090	2.28	0.065	1.65	1.086/ 1.103/ 1.120	27.59/ 28.01/ 28.45	1451	2162	590
444	1110x0.511	1110x0.0201	0.835	21.2	0.090	2.28	0.065	1.65	1.149/ 1.170/ 1.194	29.19/ 29.71/ 30.32	1697	2528	656
535	1332x0.511	1332x0.0201	0.929	23.6	0.090	2.28	0.065	1.65	1.244/ 1.272/ 1.30	31.59/ 32.31/ 33.02	2023	3015	731
646	1591x0.511	1591x0.0201	1.020	25.9	0.090	2.28	0.065	1.65	1.280/ 1.350/ 1.390	32.51/ 34.29/ 35.31	2340	3488	815



# NSHXAFÖ

## 0.6/1 to 3.6/6 kV

Standards: DIN VDE 0250 p. 606

Single conductor halogen free flexible power cables

### CONSTRUCTION

Conductors	Annealed flexible stranded tin coated or bare copper class 5 to IEC 60228, HD 383
Separator	If needed suitable tape separator between the conductor and insulation.
Insulation	Ethylene-propylene rubber (EPR) type 3GI3 to DIN VDE 0207 p. 20
Outer jacket	Halogen free thermosetting compound type HM3 to DIN VDE 0207 p. 24
Colour of outer jacket	Black or colours can be provided



105

### CHARACTERISTICS

Excellent flexibility	
Water resistant and flame retardant	
Temperature range -25°C to +90°C. For fixed installation lowest temperature is -40°C	
UV, sunlight, ozone and oil resistant	
Ink jet printed for easy identification	
Application	Heavy-duty flexible single core power cables for mobile and fixed applications
Standard length cable packing	1000 m on drums. Other forms of packing and delivery are available on request

Number and cross-sectional area of conductor	Nominal thickness of insulation	Nominal thickness of sheath	Approximate overall diameter	Approximate net weight of cables	Current-carrying capacity at 30°C in air
mm <sup>2</sup>	mm	mm	mm	kg/km	A
NSHXAFÖ 0.6/1 kV					
1x1.5	0.8	0.8	4.7	34	30
1x2.5	0.9	0.8	5.4	48	41
1x4	1.0	0.8	6.2	66	55
1x6	1.0	0.8	6.7	87	70
1x10	1.2	0.8	8.1	135	98
1x16	1.2	0.8	9.2	195	132
1x25	1.4	0.8	10.8	286	176

Number and cross-sectional area of conductor	Nominal thickness of insulation	Nominal thickness of sheath	Approximate overall diameter	Approximate net weight of cables	Current-carrying capacity at 30°C in air
mm <sup>2</sup>	mm	mm	mm	kg/km	A
1x35	1.4	1.0	11.8	379	218
1x50	1.6	1.0	14.3	545	276
1x70	1.6	1.0	16.1	738	347
1x95	1.8	1.0	18.6	964	416
1x120	1.8	1.0	19.7	1194	488
1x150	2.0	1.0	22	1480	566
1x185	2.2	1.2	25	1819	644
1x240	2.4	1.2	26.9	2339	775
1x300	2.6	1.2	30.9	2914	898
1x400	2.8	1.2	33.3	3761	1060
1x500	3.0	1.4	38.3	4737	1250
NSHXAFÖ 1.8/3 kV					
1x1.5	1.3	0.8	5.7	48	30
1x2.5	1.3	0.8	6.2	60	41
1x4	1.3	0.8	6.8	78	55
1x6	1.3	0.8	7.3	100	70
1x10	1.5	0.8	8.7	150	98
1x16	1.5	0.8	10.1	216	132
1x25	1.8	0.8	12.3	328	176
1x35	1.8	1.0	13.3	425	218
1x50	1.8	1.0	15.0	573	276
1x70	1.8	1.0	16.8	770	347
1x95	2.2	1.0	19.7	1019	416
1x120	2.2	1.0	20.8	1251	488
1x150	2.2	1.0	23.0	1547	566
1x185	2.4	1.2	25.7	1872	644
1x240	2.6	1.2	27.6	2398	775
1x300	2.8	1.2	31.6	2982	898
1x400	3.1	1.4	34.5	3847	1060
1x500	3.4	1.4	39.7	4853	1250

Number and cross-sectional area of conductor	Nominal thickness of insulation	Nominal thickness of sheath	Approximate overall diameter	Approximate net weight of cables	Current-carrying capacity at 20°C in air
mm <sup>2</sup>	mm	mm	mm	kg/km	A
NSHXAFÖ 3.6/6 kV					
1x1.5	2.6	0.8	8.3/10.5	88	13.7
1x2.5	2.6	0.8	8.8/11.5	103	8.21
1x4	2.6	0.8	9.7/12	130	5.09
1x6	2.6	0.8	10.2/13	155	3.39
1x10	2.6	0.8	11.6/14.5	215	1.95
1x16	2.6	1.0	12.7/15.5	283	1.24
1x25	2.9	1.0	14.5/17.5	393	0.795
1x35	2.9	1.0	15.2/19	489	0.565
1x50	2.9	1.0	17.2/21	651	0.393
1x70	2.9	1.0	19.0/23	856	0.277
1x95	3.2	1.0	21.7/26.5	1109	0.210
1x120	3.2	1.0	23.2/28.5	1369	0.164
1x150	3.2	1.2	25.0/30.5	1652	0.132
1x185	3.2	1.2	27.3/33	1965	0.108
1x240	3.2	1.2	29.6/34	2526	0.0817



# Opto-Telecommunication Cables For Wind Farms

108

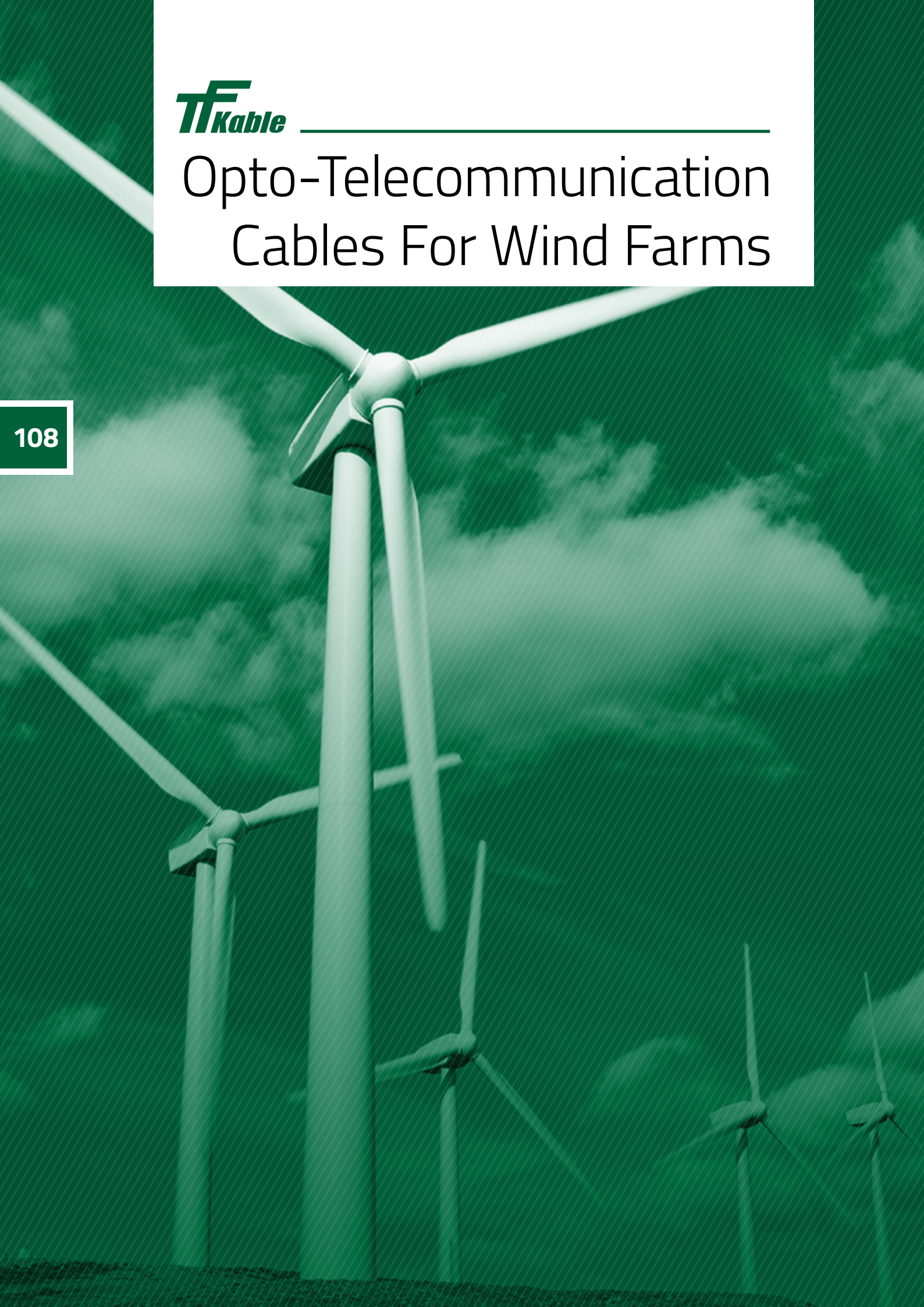

# Table of Contents

A-DQ(ZN)B2Y - loose tube	110
A-DQ(ZN)B2Y - central tube	112
Z-(VX)OTKtsdD, Z-(XV)OTKtsdD	114
ZKS-XXOTKtsFf	116
ZW-(NV)OTKtsdD	118



# A-DQ(ZN)B2Y - loose tube

Standards: VDE-0888-3

Fibre optic cable

## CONSTRUCTION

Element	typE	Material	DIMENSIONS	
Optical fibres	ITU-T G.652D or according to the attached specifications			
Identification of fibres	IEC 60304 complaint: red; green, blue, white, violet, orange, grey, yellow, brown, pink, black, turquoise			
Central strength member	Straight rod	FRP	φ 1.8 mm, 2.5 mm or 3.0 mm	
Oversheath on the central strength member	-	HDPE, black	o.d. of the central strength member	
			No. of the elements in a cable	φ of the strength member
			8	1.8 mm 2.5 mm
			12	4.1 mm 7.1 mm
Secondary coating	Loose tube contains 2, 4, 6 or 12 optical fibres	PBT	φ approx. 1.8 mm or approx. 2.4 mm	
Filling of the secondary coating	Gel	Thixotropic gel	-	
Identification of tubes or fillers	first tube: second tube the other tubes	optical fibre type E9/125 G50/125 G62.5/125	red green	
	fillers (when needed)		yellow green blue black	
Interstitial waterblocking	Dry sealing	Swelling tape	Thickness: approx. 0.15 mm	
Reinforcement	Dielectric	Glass yarn	-	
Outer sheath	-	HDPE, black	<b>Thickness:</b> min. spot: 1.6 mm average: 2.0 mm	
Attenuation @1310nm	≤ 0.4 dB/km *			
Attenuation @1550nm	≤ 0.25 dB/km *			
Marking	<b>FIBRE OPTIC CABLE A-DQ(ZN)B2Y</b> number and type of fibres <b>TF Kable1</b> year of production  length marking. Different type of marking also possible			
Production length	To be agreed; standard 4200 +/-100 m			



\* Max attenuation for SMF in cable - other parameters of the fibre according to the attached specifications

# CHARACTERISTICS

Fully dielectric	
Resistant to electromagnetic interferences	
Resistant to longitudinal water penetration	
Anti-rodent	
Can be installed in the proximity of the HV installations	
Application	Cables are designated for transmission of digital and analogue signals within the whole optical bandwidth. They can be installed in primary or secondary conduits

# PARAMETERS

No. of fibres in a cable	Tube diameter	No. of elements in a cable (tubs or tubs and fillers)	Cable dimensions		Mechanical parameters			
			Outer diameter	Weight	Max tensile load		Min. bending radius	
					Dynamic (during installation)	Static (during installation)	Dynamic (during installation)	Static (during installation)
	mm		mm	kg/km	N		mm	
up to 72	1.8	6	10.5	95	2700	1350	160	210
up to 96	1.8	8	11.6	115	2700	1350	175	230
up to 144	1.8	12	14.0	165	2700	1350	210	280
up to 72	2.4	6	12.8	130	4000	2000	190	260
up to 96	2.4	8	14.4	165	4000	2000	215	290
up to 144	2.4	12	17.4	230	4000	2000	260	350

## ADDITIONAL MECHANICAL PROPERTIES (only for cables with tubes of 2.4 mm in diameter)

Test	Standard	Value	Criteria
Crash	IEC 60794-1-2-E3	2000 N; t=15 min	$\Delta\Omega \leq 0,05$ dB @1550 N no damages
Impact	IEC 60794-1-2-E4	5 Nm, 3 impacts	$\Delta\Omega \leq 0,05$ dB @1550 N
Repeated bending	IEC 60794-1-2-E6	R=20xD; F=100 N 100 cycles, 90°, 15 cycles/min	$\Delta\Omega \leq 0,1$ dB @1550 N no damages
Torsion	IEC 60794-1-2-E7	100 N, 5 cycles, 180°	$\Delta\Omega \leq 0,05$ dB @1550 N no damages

## ENVIRONMENTAL PROPERTIES

Water penetration	IEC 60794-1-2-F5B	Sample 1 m, water head 1 m, t=24 h
Temperature range	-	Transport/storage: -40/+70°C Installation: -15/+60°C Operation: -40/+70°C



# A-DQ(ZN)B2Y - central tube

Standards: VDE-0888-3; IEC 60794-1

Fibre optic cable

## CONSTRUCTION

Element	Type	Material	Dimensions
Fibres	ITU-T G.652D or according to the attached specifications		
Identification of fibres	IEC 60304 compliant: red, green, blue, yellow, white, grey, brown, violet, turquoise, black, orange, pink Additional marking stripes above 12 fibres		
Secondary coating	Central tube 2-24 fibres	PBT	φ approx. 4.2 mm
Colour of the secondary coating	E9/125 fibres – yellow G50/125 fibres – green G62.5/125 fibres – blue		
Filling of the secondary coating	Gel	Tixotropic gel	-
Supporting elements - reinforcement	Dielectric	Water blocking glass yarns	-
Outer sheath	-	HDPE, black	<b>Thickness:</b> min. spot: 1.6 mm average: 2.0 mm
Ripcord(s)	Under the outer sheath		
Attenuation @1310 nm	≤ 0.4 dB/km *		
Attenuation @1550 nm	≤ 0.25 dB/km *		
Marking	<b>FIBRE OPTIC CABLE A-DQ(ZN)B2Y</b> number and type of fibres <b>TF Kable 1</b> year of production  length marking Different type of marking is also possible		
Standard delivery lengths	To be agreed; standard – 2000 +/- 100 m		

\* Max attenuation for SMF in cable - other parameters of the fibres according to the attached specifications



## CHARACTERISTICS

Fully dielectric

Resistant to electromagnetic interferences

Resistant to longitudinal water penetration

Can be installed in the proximity to electric installation

Easy to install

The outer sheath is made of high-density polyethylene. The marking and the metric overprint are printed on the outer sheath. Cable marking can be tailored to customer requirements

**Application** Cables are designated for transmission of digital and analogue signals within the whole optical bandwidth. They are prepared for making fast connection between optoelectronics devices, installation in cable ducts, use in places with high risk of rodents attack

# PARAMETERS

No. of fibres in a cable	Outer diameter of tube	Cable dimensions		Mechanical parameters			
		Outer diameter	Weight	Max tensile load		Min. bending radius	
				Dynamic (during installation)	Static (during installation)	Dynamic (during installation)	Static (during installation)
<b>mm</b>	<b>mm</b>	<b>kg/km</b>	<b>N</b>			<b>mm</b>	
2-24	4.2	10.0	100	2500	1250	150	200

## ADDITIONAL MECHANICAL PROPERTIES

Test	Standard	Value	Criteria
Crush	IEC 60794-1-2-E3	1500 N; t=15 min	$\Delta\Omega \leq 0,05$ dB @1550 N no damage
Impact	IEC 60794-1-2-E4	5 Nm, 3 impacts	$\Delta\Omega \leq 0,05$ dB @1550 N
Repeated bending	IEC 60794-1-2-E6	R=20xD; F=100 N 100 cycles, 90°, 15 cycles/min	$\Delta\Omega \leq 0,1$ dB @1550 N no damage
Torsion	IEC 60794-1-2-E7	100 N, 5 cycles, 180°	$\Delta\Omega \leq 0,05$ dB @1550 N no damage

## ENVIRONMENTAL SPECIFICATIONS

Water penetration	IEC 60794-1-2-F5B	Sample 1 m, water head 1 m, 24 hours
Temperature range	-	Transport/storage: -25/+70°C Installation: -15/+55°C Operation: -25/+60°C



# Z-(VX)OTKtsdD, Z-(XV)OTKtsdD

Fibre optic cable

## CONSTRUCTION

Element	typE	Material	DIMENSIONS		
Optical fibres	ITU-T G.652D or according to the attached specifications				
Identification of fibres	IEC 60304 complaint: red, green, blue, white, violet, orange, grey, yellow, brown, pink, black, turquoise				
Central strength member	Rod	FRP	φ 1.8 mm, 2.5 mm or 3.0 mm		
Oversheath on the central strength member	-	HDPE, black	o.d. of the central strength member		
			No. of the elements in a cable	φ of the strength member	
				8	-
			12	5.3 mm	7.1 mm
			24	3.5 mm	4.9 mm
Secondary coating	Loose tube contains 2-12 optical fibres	PBT	φ 1.8 or approx. 2.4 mm		
Filling of the secondary coating	GEL	Thixotropic gel	-		
Identification of tubes or fillers	first tube: second tube the other tubes fillers (when needed) The colour sequence repeats in every layer		red blue natural black		
Interstitial waterblocking	Dry sealing	Swelling tape	Thickness: approx. 0.15 mm		
Reinforcement	Dielectric	Aramid	-		
Outer sheath – 1 <sup>st</sup> layer (inner)	-	HDPE, black	<b>Thickness:</b> spot: 1.0 mm average: 1.2 mm		
Outer sheath – 2 <sup>nd</sup> layer	-	Polyamide, orange	<b>Thickness:</b> spot: 0.7 mm average: 0.8 mm		
In case of Z-(XV)OTKtsdD cable the 1st and 2nd layer of the outer sheath are swapped, i.e. the HDPE is the outermost layer					
Attenuation@1310 nm	≤ 0.4 dB/km *				
Attenuation@1550 nm	≤ 0.25 dB/km *				
Marking	<b>FIBRE OPTICAL CABLE Z-(VX)OTKtsdD</b> number and type of fibres <b>TF Kable 1</b> year of production  length marking Different type of marking is also possible				
Production length	To be agreed; standard – 4200 +/- 100 m				

\* Max attenuation for SMF in cable - other parameters of the fibre according to the attached specifications



# CHARACTERISTICS

Fully dielectric	
Resistant to electromagnetic interferences	
Resistant to longitudinal water penetration	
Flame retardant, low smoke emission, zero halogen	
Anti-rodent	
Can be installed in the proximity of the electric installation	
A cable with the outermost layer of HDPE is UV resistant	
Application	Cables are designated for transmission of digital and analogue signals within the whole optical bandwidth. They can be applied to optoelectronic devices interconnections, installed in cable ducts and in the places of the high risk of rodent damage. The cables can be also hang on poles of telephone lines, MV and LV power lines, and they can be installed in the proximity of the HV lines

# PARAMETERS

No. of fibres in a cable	Tube diameter	No. of elements in a cable (tubs or tubs and fillers)	Cable dimensions		Mechanical parameters			
			Outer diameter	Weight	Max tensile load		Min. bending radius	
					Dynamic (during installation)	Static (during installation)	Dynamic (during installation)	Static (during installation)
	mm		mm	kg/km	N		mm	
4-72	1.8	6	10.2	85	2700	1350	150	200
28-96	1.8	8	11.4	105	3000	1500	170	230
36-144	1.8	12	13.7	150	4000	2000	210	270
52-216	1.8	18	14.1	150	4000	2000	210	280
76-288	1.8	24	15.8	185	4000	2000	240	320
4-72	2.4	6	12.2	115	4000	2000	180	240
28-96	2.4	8	13.8	145	5000	2500	210	280
36-144	2.4	12	16.8	215	6000	3000	250	340
52-216	2.4	18	17.3	225	6000	3000	260	340
76-288	2.4	24	19.5	290	6000	3000	290	390

# ENVIRONMENTAL PROPERTIES

Water penetration	IEC 60794-1-2-F5B	Sample 1 m, water head 1 m, t=24 h
Temperature range	-	Transport/storage: -40/+70°C Installation: -15/+60°C Operation: -40/+70°C



# ZKS-XXOTKtsFf

Fibre optic cable

## CONSTRUCTION

Element	typE	Material	DIMENSIONS	
Optical fibres	ITU-T G.652D or according to the attached specifications			
Identification of fibres	IEC 60304 compliant: red, green, blue, white, violet, orange, grey, yellow, brown, pink, black, turquoise			
Central strength member	Rod	FRP	φ 1.8 mm, 2.5 mm or 3.0 mm	
			O.D. of the central strength member	
Oversheath on the central strength member	-	HDPE	No. of the elements in a cable	φ of the strength member
			8	1.8 mm 2.5 mm
			12	5.3 mm 7.1 mm
			24	3.5 mm 4.9 mm
Secondary coating	Loose tube contains 2-12 optical fibres	PBT	φ 1.8 or approx. 2.4 mm	
Filling of the secondary coating	Gel	Thixotropic gel	-	
Identification of tubes or fillers	First tube: Second tube: The other tubes: Fillers (when needed): black The colour sequence repeats in every layer		red blue natural black	
Interstitial waterblocking	Dry sealing	Swelling tape	Thickness: approx. 0.15 mm	
Inner sheath	-	HDPE	<b>Thickness:</b> minimal: 0.45 mm average: 0.55 mm	
Armouring	Steel	Steel tape covered with a copolymer	Thickness: 0.25 mm	
Outer sheath	-	HDPE, black	<b>Thickness:</b> min spot: 1.55 mm average: 1.70 mm	
Attenuation@1310 nm	≤ 0.4 dB/km *			
Attenuation@1550 nm	≤ 0.25 dB/km *			
Marking	<b>FIBRE OPTICAL CABLE ZKS-XXOTKtsFf</b> number and type of fibres <b>TF Kable 1</b> year of production  length marking. Different type of marking is also possible			
Production length	To be agreed; standard – 2100 +/- 100 m			

\* Max attenuation for SMF in cable - other parameters of the fibre according to the attached specifications



# CHARACTERISTICS

Fully dielectric	
Anti-rodent	
Resistant to electromagnetic interferences	
Resistant to abrasion, UV and fatigue corrosion	
Resistant to longitudinal water penetration	
Due to corrugated steel tape a cable is flexible yet resistant to transverse stress and rodent attacks	
Application	Cables are designated for transmission of digital and analogue signals within the whole optical bandwidth. They can be installed in primary or secondary conduits or directly in ground in mines or places of high risk of mechanical damage

# PARAMETERS

No. of fibres in a cable	Tube diameter	No. of elements in a cable (tubs or tubs and fillers)	Cable dimensions		Mechanical parameters			
			Outer diameter	Weight	Max tensile load		Min. bending radius	
					Dynamic (during installation)	Static (during installation)	Dynamic (during installation)	Static (during installation)
	mm		mm	kg/km	N		mm	
4-72	1.8	6	12.3	140	1000	500	180	250
28-96	1.8	8	13.5	180	1500	750	200	270
36-144	1.8	12	15.8	240	2200	1100	240	320
52-216	1.8	18	16.2	255	1000	500	240	320
76-288	1.8	24	17.9	300	2500	1250	270	360
4-72	2.4	6	14.2	185	2700	1350	210	280
28-96	2.4	8	15.8	230	2700	1350	240	320
36-144	2.4	12	18.8	305	2700	1350	280	380
52-216	2.4	18	19.3	315	2700	1350	290	390
76-288	2.4	24	21.5	385	2700	1350	320	430

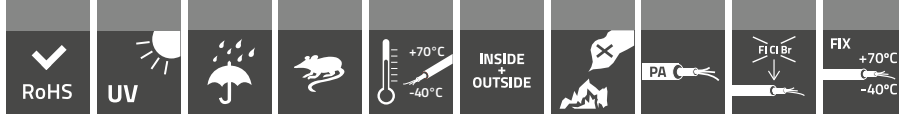

# ZW-(NV)OTKtsdD

Fibre optic cable

## CONSTRUCTION

Element	Type	Material	Dimensions
Optical fibres	ITU-T G.652D or according to the attached specifications		
Identification of fibres	IEC 60304 compliant: red, green, blue, white, violet, orange, grey, yellow, brown, pink, black, turquoise		
Central strength member	Straight rod	FRP	φ 2.5 mm
Oversheath on the central strength member	-	HDPE, Black	8 elements φ 4.1 mm 12 elements φ 7.1 mm 24 elements φ 4.9 mm
Secondary coating	Loose tube contains 2, 4, 6 or 12 optical fibres	PBT	φ approx. 2.4 mm
Identification of tubes or fillers	First tube: Second tube: The other tubes: Fillers (when needed):		red blue natural black
Filling of the secondary coating	GEL	Thixotropic gel	-
Interstitial waterblocking	Dry sealing	Swelling tape	Thickness: approx. 0.15 mm
Reinforcement	Dielectric	Aramid yarn	-
Outer sheath – 1 <sup>st</sup> layer	-	Polyamide 12	<b>Thickness:</b> spot: 0.7 mm average: 0.8 mm
Outer sheath – 2 <sup>nd</sup> layer	-	LSOH, black	<b>Thickness:</b> spot: 1.1 mm average: 1.2 mm
Attenuation@1310 nm	≤ 0.4 dB/km *		
Attenuation@1550 nm	≤ 0.25 dB/km *		
Marking	<b>FIBRE OPTICAL CABLE ZW-(NV)OTKtsdD</b> number and type of fibres <b>TF Kable 1</b> year of production  length marking Different type of marking also possible		
Production length	To be agreed, standard – 4200 +/- 100 m		

\* Max attenuation for SMF in cable - other parameters of the fibre according to the attached specifications



# CHARACTERISTICS

Fully dielectric	
Resistant to electromagnetic interferences	
Resistant to longitudinal water penetration	
Flame retardant. Low smoke emission. Halogen free	
Anti-rodent	
Can be installed in the proximity of the electric installation	
Application	Cables are designated for transmission of digital and analogue signals within the whole optical bandwidth. They can be installed in residential buildings, trenches, tunnels, on walls or by means of hanging.

# PARAMETERS

No. of fibres in a cable	Tube diameter	No. of elements in a cable (tubs or tubs and fillers)	Cable dimensions		Mechanical parameters			
			Outer diameter	Weight	Max tensile load		Min. bending radius	
					Dynamic (during installation)	Static (during installation)	Dynamic (during installation)	Static (during installation)
	mm		mm	kg/km	N		mm	
4-72	2.4	6	12.2	140	4000	2000	180	240
28-96	2.4	8	13.8	175	5000	2500	210	280
36-144	2.4	12	16.8	250	6000	3000	250	340
52-216	2.4	18 (6+12)	17.3	260	6000	3000	260	340
76-288	2.4	24 (9+15)	19.5	325	6000	3000	290	390

# ENVIRONMENTAL PROPERTIES

Water penetration	IEC 60794-1-2-F5B	Sample 1 m, water head 1 m, t=24 h
Temperature range	-	Transport/storage: -40/+70°C Installation: -15/+60°C Operation: -40/+70°C

# CABLE DRUMS

## Sample data of wooden cable drums.

Approximate capacity wooden cable drums - amount of cable (in running metres) on sample cable drums.

Cable diameter [mm]	Type of sample cable drum						
	28	30	32	34	37	40	43
57	1 060	1 420	2 600	2 220	2 890	4 080	4 930
58	1 060	1 420	2 520	2 150	2 820	3 970	4 800
59	1 020	1 380	2 270	2 150	2 820	3 590	4 800
60	1 020	1 380	2 270	2 150	2 750	3 490	4 700
61	970	1 330	2 210	2 090	2 750	3 490	4 300
62	970	1 330	2 210	1 820	2 330	3 400	4 180
63	970	1 330	2 150	1 760	2 330	3 400	4 180
64	970	1 290	1 900	1 760	2 270	2 950	4 080
65	780	1 080	1 840	1 700	2 270	2 950	4 080
66	780	1 030	1 840	1 700	2 200	2 870	3 590
67	780	1 030	1 840	1 700	2 200	2 870	3 590
68	740	1 030	1 790	1 650	2 140	2 790	3 500
69	740	1 000	1 790	1 410	1 830	2 790	3 500
70	740	1 000	1 790	1 410	1 830	2 790	3 500
71	740	1 000	1 520	1 360	1 780	2 390	3 060
72	710	960	1 520	1 360	1 780	2 390	3 060
73	710	960	1 520	1 360	1 720	2 320	2 960
74	710	960	1 470	1 310	1 720	2 320	2 960
75	710	960	1 470	1 310	1 720	2 320	2 960
76	540	740	1 470	1 310	1 660	2 250	2 880
77	540	740	1 420	1 260	1 660	2 250	2 880
78	540	740	1 220	1 260	1 660	1 960	2 570
79	540	740	1 220	1 050	1 340	1 880	2 480
80	540	710	1 220	1 050	1 340	1 880	2 480
81	520	710	1 180	1 010	1 340	1 880	2 480
82	520	710	1 180	1 010	1 290	1 820	2 390
83	520	710	1 180	1 010	1 290	1 820	2 390
84	520	680	1 180	1 010	1 290	1 820	2 390
85	520	680	1 130	970	1 290	1 820	2 390
86	490	680	1 130	970	1 250	1 760	2 030
87	490	680	1 130	970	1 250	1 760	2 030
88	490	650	960	970	1 250	1 500	2 030
89	490	650	920	920	1 250	1 500	2 030

Cable diameter [mm]	Type of sample cable drum						
	28	30	32	34	37	40	43
90	490	650		920	1 200	1 440	1 960
91	380	500		920	1 200	1 440	1 960
92	350	500		750	970	1 440	1 960
93	350	470		750	970	1 440	1 960
94	350	470		710	930	1 380	1 890
95		470		710	930	1 380	1 630
96		470		710	930	1 380	1 630
97		470		710	930	1 380	1 630
98		470		710	930	1 380	1 630
99		450		670	890	1 330	1 570
100		450		670	890	1 330	1 570
101		450		670	890	1 110	1 570
102		450		670	890	1 110	1 570
103		450		670	890	1 110	1 570
104		450		670	850	1 060	1 500
105		450		670	850	1 060	1 500
106				640	850	1 060	1 500
107				640	850	1 060	1 280
108				640	850	1 060	1 280
109				640	810	1 010	1 220
110				640	810	1 010	1 220
111				490	630	1 010	1 220
112				490	630	1 010	1 220
113				460	630	1 010	1 220
114				460	630	1 010	1 220
115				460	630	1 010	1 220
116					590	960	1 160
117					590	770	1 160
118					590	770	1 160
119					590	770	1 160
120					590	770	1 160
121					590	780	1 160
122					590	780	970
123					560	730	910
124					560	730	910
125					560	730	910
126					560	730	910
127					560	730	910
128					560	730	910
129					560	730	910
130					560	730	910
131					530	690	860

# CABLE DRUMS

## Sample data of wooden cable drums.

Sample data regarding wooden cable drums.

Type		28	30	32	34	37	40	43
Ø D	mm	2800	3000	3200	3400	3700	4000	4300
Ø D1	mm	1800	2000	1700	2200	2500	2500	2500
B	mm	1400	1700	1800	1800	2100	2100	2100
L	mm	1675	1990	2095	2200	2500	2500	2500
Weight	kg	1370	1798	1814	2500	4250	4690	5170

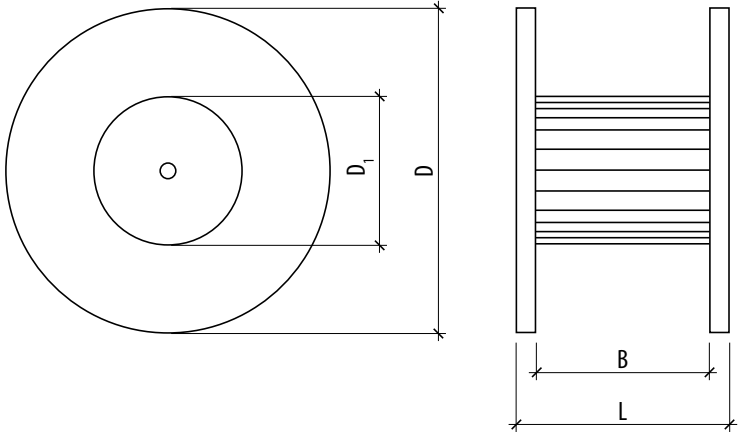

Note: Figures used are indicative and may vary due to manufacturing tolerances, so should only be used as guidance.





TELE-FONIKA Kable S.A.,  
ul. Hipolita Cegielskiego 1  
32-400 Myślenice, Poland  
T. (+48) 12 652 5000  
F. (+48) 12 652 5156

[info@tfkable.com](mailto:info@tfkable.com)

[www.tfkable.com](http://www.tfkable.com)

Edition II

---

All the information contained in this document - including tables, graphics and diagrams - is given in good faith and believed to be correct at the time of publication. The information does not constitute a warranty nor representation for which TELE-FONIKA Kable assumes legal responsibility. TELE-FONIKA Kable reserves rights to introduce changes to the document at any time.

All Rights Reserved – TELE-FONIKA Kable SA