

The product family TerraMo of the underground systems convinces with its multiplicity of positive features. Public areas keep their flexible usability if those units will be built in inner areas like shopping malls, offices, conference centers or exhibition halls.

Due to the integrated climate control the units can also be used every season in outdoor areas like parkways, on market places or on terraces.

TerraMo with
pneumatic spring





The compact and attractive design is extremely space-saving and easy to integrate. The closed complete unit convinces with a simple and quick assembly. The lifting mechanism with gas pressure spring enables a comfortable operation. A high safety standard is warranted by the use of an earth leakage circuit breaker and a pre-fuse. Due to its robust construction it is possible to passing over the retracted unit by car.

The competent counseling at design, assembly and maintenance, the excellent converting "Made in Germany" as well as the low installation costs, working costs and the superior high endurance, enthuse the architects, builder and electrical engineers.



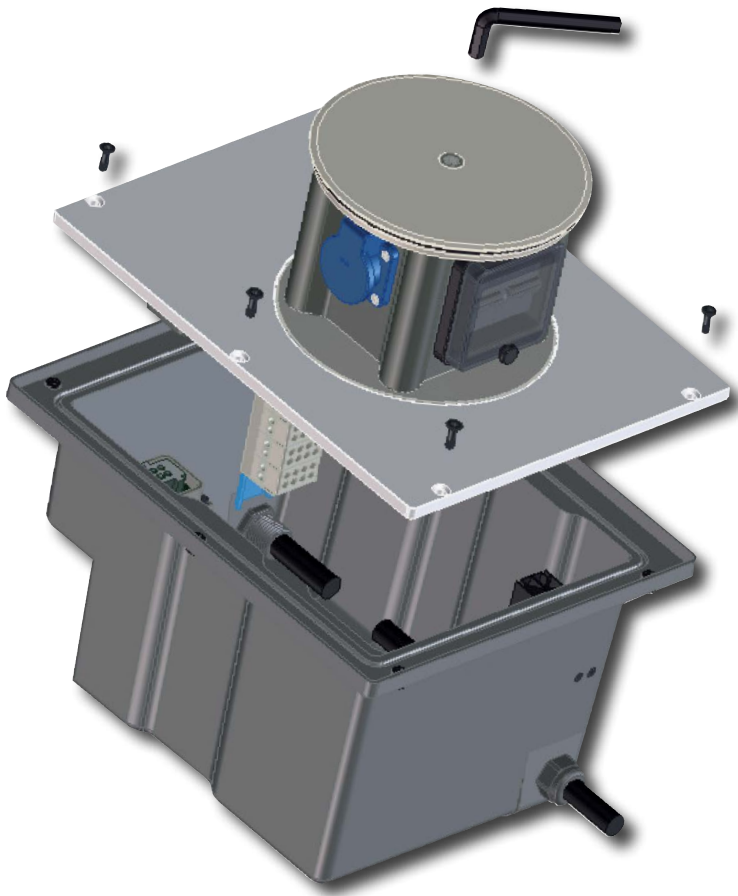

TerraMo with pneumatic spring

Technical data

Protection class:	IP 44 for sockets IP 55 for distributors
Protection equipment:	Protective conductor, protection class 1
Mains voltage / frequency:	230/400V, 50 Hz
Network:	TN-S system
Connection load:	approx. 3 kW
Max. permissible supply cable:	5 x 6 mm ²
Total weight:	11 kg
Dimensions: (HxWxD):	303 x 390 x 310 mm
Installation depth:	303 mm
Extendible height::	136 mm
Load capacity of cover:	Supports weight of car
Heater:	20W switch cabinet heater
Lifting mechanism:	pneumatic spring
Drainage connection:	1 St. DN 40

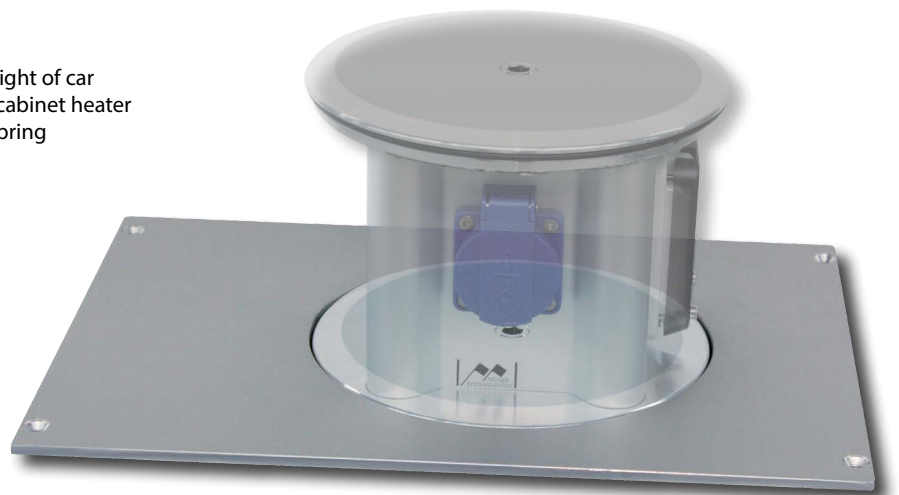

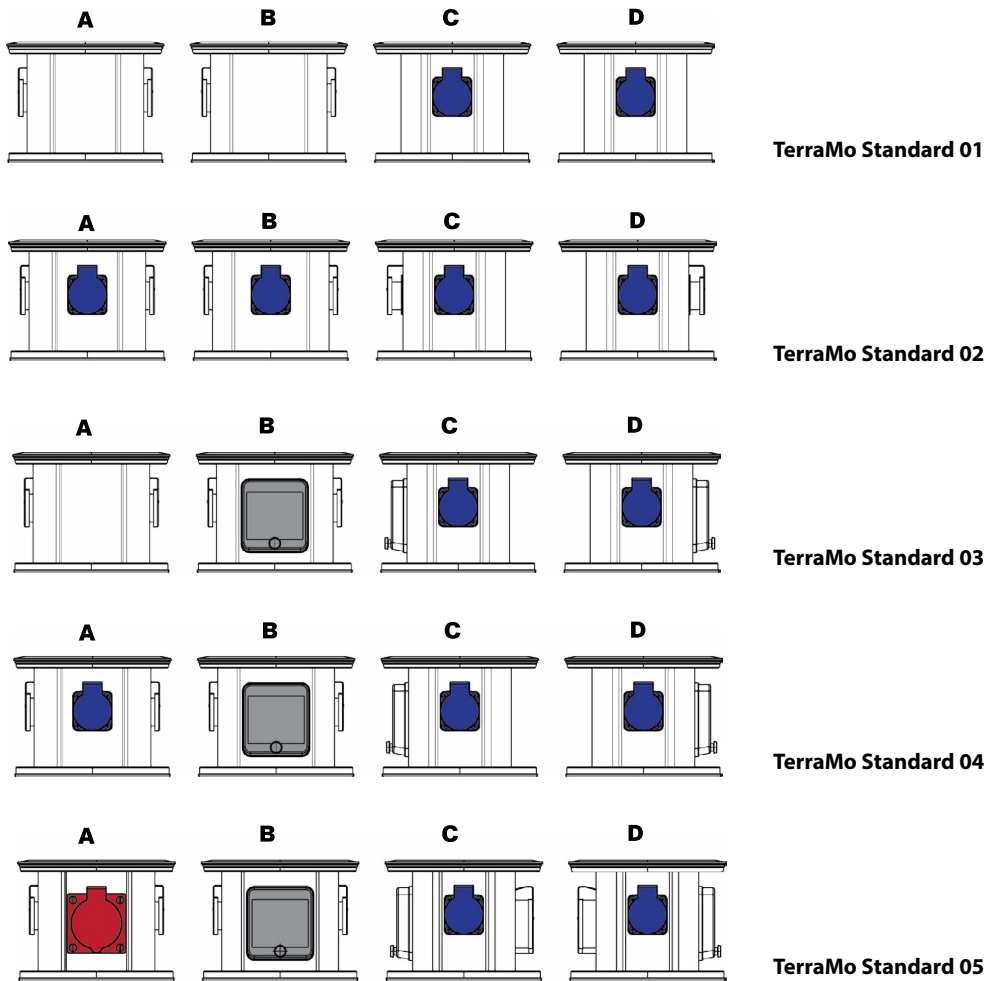

Description	Equipment	Article description	Order-No.
TerraMo Standard 01	2 protective contact sockets, 16 A	TerraMo-Sta-01	M502010001
TerraMo Standard 02	4 protective contact sockets, 16 A	TerraMo-Sta-02	M502010002
TerraMo Standard 03	2 protective contact sockets, 16 A 1 distributor 4 partitions	TerraMo-Sta-03	M502010003
TerraMo Standard 04	3 protective contact sockets, 16 A 1 distributor 4 partitions	TerraMo-Sta-04	M502010004
TerraMo Standard 05	2 protective contact sockets, 16 A, 1 CEE 16 A 1 distributor 4 partitions	TerraMo-Sta-05	M502010005

Further informations you'll find on page 102/103

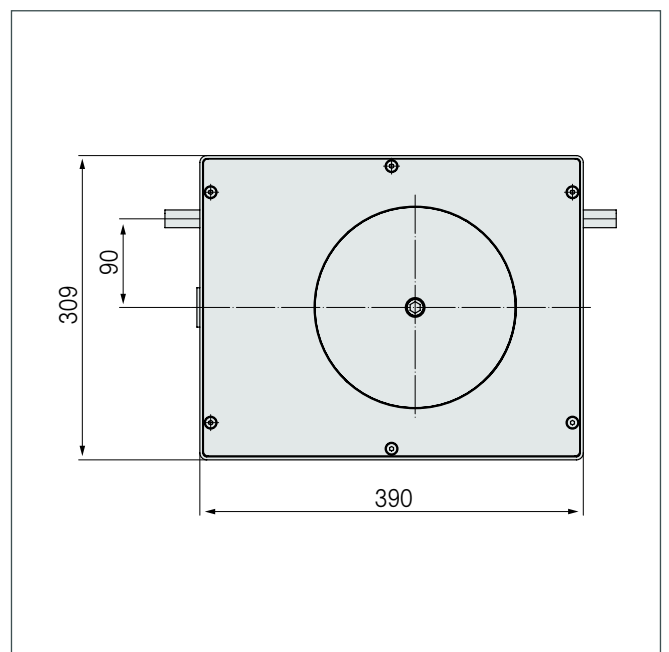
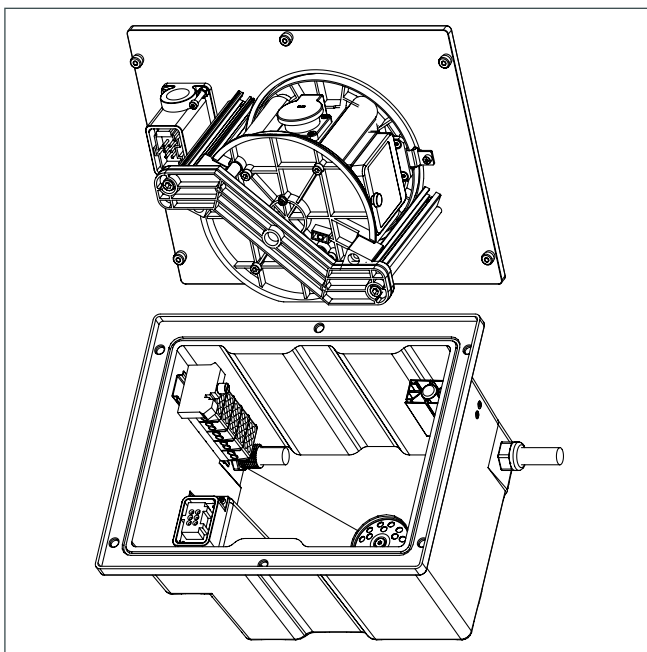
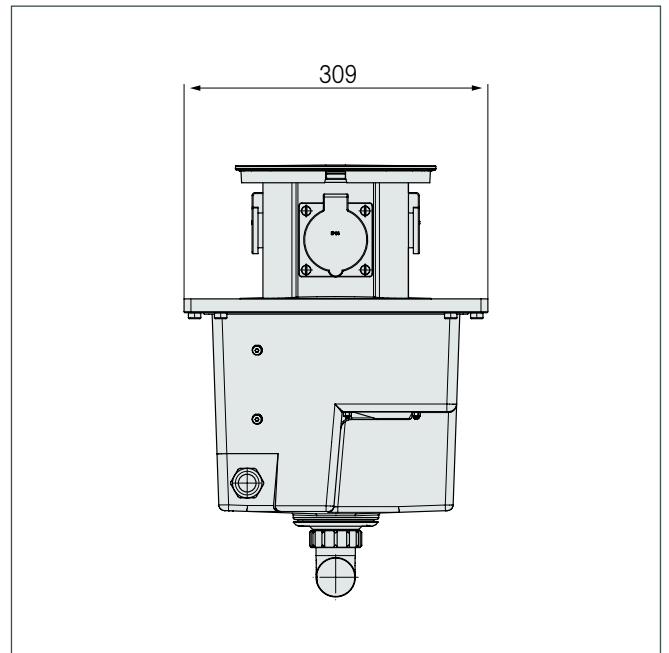
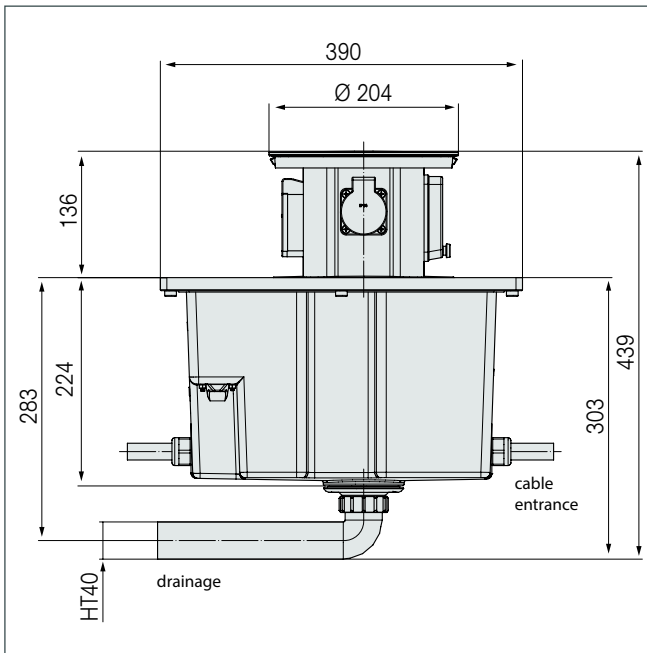

Measures in mm

Airport technology

Thanks to existing know-how and continuous further development, MOSER has developed a retractable supply post series specially for airports. These retractable supply posts are equipped with modern equipment for handling and maintaining aircraft both in hangars and on the airfield:

- Standard 50 Hz network supply
- Movable devices
- 400 Hz technology
- Testing devices
- Compressed air
- Data lines
- Water and waste water
- Electrical and pneumatic tools
- Water- and compressed air hoses
- Conditioned air